

**DOMESTIC CATALOGUE**

**2022 EDITION**



**PowerMax<sup>®</sup>**  
Fitness

# PowerMax Fitness

WE ARE PRESENT GLOBALLY



- NUMBERS DENOTE:
- |                            |                        |                    |
|----------------------------|------------------------|--------------------|
| 1 - Luxemburg              | 12 - Djibouti          | 24 - Armenia       |
| 2 - Bosnia and Herzegovina | 13 - Gambia            | 25 - Bhutan        |
| 3 - Montenegro             | 14 - Guinea-Bissau     | 26 - Bangladesh    |
| 4 - Albania                | 15 - Sierra Leone      | 27 - Cambodia      |
| 5 - Macedonia (FYROM)      | 16 - Togo              | 28 - Singapore     |
| 6 - Moldova                | 17 - Equatorial Guinea | 29 - Brunei        |
| 7 - Cyprus                 | 18 - Cabinda (Angola)  | 30 - Belize        |
| 8 - Lebanon                | 19 - Rwanda            | 31 - Honduras      |
| 9 - Israel                 | 20 - Burundi           | 32 - El Salvador   |
| 10 - Kuwait                | 21 - Malawi            | 33 - Costa Rica    |
| 11 - United Arab Emirates  | 22 - Swaziland         | 34 - Suriname      |
|                            | 23 - Lesoto            | 35 - French Guiana |

# INDIA

- |                       |                   |
|-----------------------|-------------------|
| 1. Andhra Pradesh     | 17. Maharashtra   |
| 2. Arunachal Pradesh  | 18. Manipur       |
| 3. Assam              | 19. Meghalaya     |
| 4. Bihar              | 20. Mizoram       |
| 5. Chandigarh         | 21. Nagaland      |
| 6. Chhattisgarh       | 22. Odisha        |
| 7. Delhi              | 23. Punjab        |
| 8. Goa                | 24. Puducherry    |
| 9. Gujarat            | 25. Rajasthan     |
| 10. Haryana           | 26. Sikkim        |
| 11. Himachal Pradesh  | 27. Tamil Nadu    |
| 12. Jammu and Kashmir | 28. Telangana     |
| 13. Jharkhand         | 29. Tripura       |
| 14. Karnataka         | 30. Uttar Pradesh |
| 15. Kerala            | 31. Uttarakhand   |
| 16. Madhya Pradesh    | 32. West Bengal   |

- |  |                      |
|--|----------------------|
|  | SINGAPORE            |
|  | AUSTRALIA            |
|  | EGYPT                |
|  | SRILANKA             |
|  | NEPAL                |
|  | QATAR                |
|  | SAUDI ARABIA         |
|  | TRINIDAD AND TOBAGO  |
|  | UNITED ARAB EMIRATES |
|  | UNITED KINGDOM       |
|  | KUWAIT               |
|  | BELGIUM              |
|  | USA                  |



## Mission Statement

At PowerMax we are passionate about exercise and wellness. Fitness is of the utmost importance in this day and lifestyle. More and more of us lead more sedentary, office-based lives as computers dominate many professions. Our goal at PowerMax is to Spread fitness awareness and get you fitter by making it as easy and as fun as possible for a longer, healthier, happier life.....

## Spiritual Mission Statement

1. Make people mentally fit by spreading Fitness awareness, motivating them to lead a healthier life through exercise
2. Giving detailed insights into the benefits of exercise, making individuals motivated to make fitness part of routine life.
3. Reduce medical cost and pain in people's life by promoting fitness.
4. Convey effectively the idea of how a healthy body contributes to a healthy mind and a peaceful life.

## Business Mission Statement & Guiding Area

1. Provide the highest quality of Health and Fitness Products which guarantee the safety and satisfying user experience.
2. Make affordable fitness equipment so all individuals have the privilege of being fit.
3. Consider the troubles and concerns of every customer and help them in terms of service support, installation, how to use and make the most effective use of the machine.
4. Make fitness equipment available in each nook and corner of the Planet Earth

## PowerMax Fitness is now ISO 9001:2015 Certified for Quality Assurance





# MT-1M

## IRONMAN

**Specification** Motorized Treadmill with Android & iOS Application

Motor	4.0HP Peak DC Motor
Max User Weight	100KG
Running Surface	1210X410mm / 47.6X16.1inches
Inclination	2 Level Manual Incline
Speed	1.0 - 14km/Hr
Display	10cm LCD Display - Time, Speed, Distance, Heart rate, Calories, Program
Shock Absorption	ComfortTech 6-Point damping system with Double Layer Running Board

Running Belt	Anti-slip texture diamond wave running belt
Connectivity	Connect Treadmill via Bluetooth with Android & iOS App, MP3, AUX input, Hi-Fi Speaker
Program	12 Pre-set Programs for efficient workout & 3 Target based Modes
Foldable	Hydraulic Softdrop System (HSS)
Other Features	Semi-Auto Lubrication-BMI/Fat, Foldable, Mobile, Bottle & Accessories Holder & wheels for transportation.
Warranty	Lifetime frame warranty, 3 years motor warranty and 1 year parts and labour warranty



PowerMax®

MARVEL



# MT-1A

## CAPTAIN AMERICA

**Specification** Motorized Treadmill with Android & iOS Application

Motor	4.0HP Peak DC Motor
Max User Weight	100KG
Running Surface	1210X410mm / 47.6X16.1inches
Inclination	15 Levels Auto Incline
Speed	1.0 - 14km/Hr
Display	10cm LCD Display - Time, Speed, Distance, Heart rate, Calories, Program
Shock Absorption	ComfortTech 6-Point damping system with Double Layer Running Board

Running Belt	Diamond Wave Running Belt
Connectivity	Connect Treadmill via Bluetooth with Android & iOS App, MP3, AUX input, Hi-Fi Speaker
Program	12 Pre-set Programs for efficient workout & 3 Target based Modes
Foldable	Hydraulic Softdrop System (HSS)
Other Features	Semi-Auto Lubrication-BMI/Fat, Foldable, Mobile, Bottle & Accessories Holder & wheels for transportation.
Warranty	Lifetime frame warranty, 3 years motor warranty and 1 year parts and labour warranty





# MTM-1000M CAPTAIN AMERICA

## Specification Semi-Auto Lubrication Multifunction Treadmill

Motor 4.0HP Peak DC Motor

Max User Weight 105KG

Running Surface 1260X430mm / 49.6X16.9inches

Inclination 6 Level Manual Incline

Speed 0.8-14.8km/Hr

Display 12.7cm LED Display - Time, Speed, Distance, Calories & Heart Rate

Shock Absorption Dual spring shock absorbtion with double layer running board

Running Belt Grass Texture Running Belt

Connectivity AUX USB input

Program 12 pre-set programs with Heart rate sensors on crossbar handle

Foldable Hydraulic Softdrop System (HSS)

Multifunction Massager & Sit-up

Other Features Semi-Auto lubrication, Wheels for transportation and Easy to Install

Warranty 1-year parts warranty, 3 years motor replacement warranty. Lifetime frame warranty.





# MTA-1000 CAPTAIN AMERICA

### Specification      Semi Auto lubrication Motorized Treadmill with Auto Incline

Motor	4.0HP Peak DC Motor
Max User Weight	110KG
Running Surface	1260X430mm / 49.6X16.9inches
Inclination	15 Levels Auto Incline
Speed	0.8-14.8km/Hr
Display	12.7cm LED Display - Time, Speed, Distance, Calories & Heart Rate
Shock Absorption	Dual spring shock absorbtion with double layer running board

Running Belt	Grass Texture Running Belt
Connectivity	AUX USB input
Program	12 pre-set programs with Heart rate sensors on crossbar handle
Foldable	Hydraulic Softdrop System (HSS)
Other Features	Semi-Auto lubrication, Wheels for transportation and Easy to Install
Warranty	Lifetime frame warranty, 3 years motor warranty and 1 year parts and labour warranty





# MTA-2300

## CAPTAIN AMERICA

**Specification** Motorized Treadmill with Semi-Auto Lubrication

Motor	4.0HP Peak DC Motor
Max User Weight	115KG
Running Surface	1260X420mm / 49.6X16.5inches
Inclination	15 Level Auto Incline
Speed	1.0 - 14km/Hr
Display	14cm LCD Display-Time, Speed, Distance, Incline, Calories & Heart rate, BMI / Fat
Shock Absorption	Dual spring shock absorption equipped with ComfortTech™ - 6 point commercial grade damping system.

Running Belt	Multi-ply polyester satin weave with a PVC non-slip surface of 1.8mm thickness
Connectivity	AUX & USB input.
Program	12 Pre-set workout & 3 target based modes.
Foldable	Hydraulic Softdrop System (HSS)
Other Features	Wheel for transportation, Semi-Auto lubrication & Easy to install, iPad Holder, Hi-Fi Speaker
Warranty	Lifetime frame Warranty, 3-year motor Warranty, and 1-Year Parts & Labor Warranty.





# MTA-2300M

## IRONMAN

**Specification** Motorized Treadmill with Semi-Auto Lubrication

Motor	4.0HP Peak DC Motor
Max User Weight	115KG
Running Surface	1260X420mm / 49.6X16.5inches
Inclination	15 Level Auto Incline
Speed	1.0 - 14km/Hr
Display	14cm LCD Display-Time, Speed, Distance, Incline, Calories & Heart rate, BMI / Fat
Shock Absorption	Dual spring shock absorption equipped with ComfortTech™ - 6 point commercial grade damping system.

Running Belt	Multi-ply polyester satin weave with a PVC non-slip surface of 1.8mm thickness
Connectivity	AUX & USB input.
Program	12 Pre-set workout & 3 target based modes.
Foldable	Hydraulic Softdrop System (HSS)
Other Features	Wheel for transportation, Semi-Auto lubrication & Easy to install, iPad Holder, Hi-Fi Speaker
Multifunction	Massager, Sit-ups, Dumbbells & Twister for waist
Warranty	Lifetime frame Warranty, 3-year motor Warranty, and 1-Year Parts & Labor Warranty.





# MTM-2500 IRONMAN

**Specification** Motorized Treadmill with Automatic Lubrication & Jumping Wheels

<b>Motor</b>	4.0HP Peak DC Motor	<b>Running Belt</b>	Diamond wave running belt
<b>Max User Weight</b>	110KG	<b>Connectivity</b>	MP3, AUX input
<b>Running Surface</b>	1210X410mm / 47.6X16.1inches	<b>Program</b>	12 Pre-set Programs for efficient workout & 3 Target based Modes
<b>Inclination</b>	15 Level Auto Incline	<b>Foldable</b>	Hydraulic Softdrop System (HSS)
<b>Speed</b>	1.0 - 14km/Hr	<b>Other Features</b>	Wheels for transportation, Hi-Fi Speaker,
<b>Display</b>	5inch LED Display - Time, Speed, Distance, Heart rate, Calories, Program	<b>Warranty</b>	Lifetime frame warranty, 3 years motor warranty and 1-year parts and labor warranty
<b>Shock Absorption</b>	Dual jumping wheels with double layer running board		





# MTC-3600 CAPTAIN AMERICA

## Specification AC Motorized Treadmill with Auto Lubrication and Auto Incline

Motor	3.0HP AC Motor
Max User Weight	140KG
Running Surface	1350X480mm / 53.1X18.8inches
Inclination	15 Levels Auto incline
Speed	1.0-18km/hr
Display	17.7cm LCD Display-Time, Speed, Distance, Calories, Heart rate, BMI / Fat
Shock Absorption	Dual spring shock absorption system with ComfortTech™ - 6 point commercial grade damping system to reduce stress on your joints.

Running Belt	3.2 Diamond wave running belt
Connectivity	AUX & USB input
Program	12 pre-set programs & 3 target based modes
Foldable	Hydraulic Softdrop System (HSS)™
Other Features	Auto Lubrication, Easy Installation and Wheel for transportation, Hi-Fi Speaker
Warranty	Lifetime frame warranty, 3 years motor warranty and 1-year parts and labor warranty.





# MB-145 IRONMAN

## Specification Exercise Spin Bike for Home Use

Flywheel	8KG
Max User Weight	120KG
Drive System	Belt Drive
Resistance	Adjustable resistance with a press down brake system
Display	LCD Display - Scan, Speed, Time, Distance, RPM, Calories, Hand Pulse, Odometer
Seat	Fully adjustable soft seat (Vertically and Horizontally)

Pedals	Anti-slip pedals with adjustable foot strap
Handle	HDR Foam Grip Handle
Heart rate sensor	Heart rate sensor on handle bar
Other Features	Wheels for easy transportation
Warranty	1 Year Manufacturer Warranty





**MB-165**  
CAPTAIN  
AMERICA

**Specification** Exercise Spin Bike for Home Use

Flywheel	13KG
Max User Weight	120KG
Drive System	Belt Drive
Resistance	Adjustable resistance with a press down brake system
Display	LCD Display - Scan, Speed, Time, Distance, RPM, Calories, Hand Pulse, Odometer
Seat	Fully adjustable soft seat (Vertically and Horizontally)

Pedals	Anti-slip pedals with adjustable foot strap
Handle	HDR Foam Grip Handle
Heart rate sensor	Heart rate sensor on handle bar
Other Features	Wheels for easy transportation
Warranty	1 Year Manufacturer Warranty



# BCA-130

CAPTAIN AMERICA  
WEIGHT SCALE



## APP FEATURES:

APP support Android & iOS

Weighing Reminder

Unlimited number of User

Auto recognize family Members

Auto LB/KG/ST recognition

Cloud-based data storage to ensure safety

Connect to Apple health kit/Google Fit/Fitbit and more

Password App Lock to ensure privacy

Calendar-based history review

Social sharing of measurement and moments



# BCA-130

IRONMAN  
WEIGHT SCALE



## APP FEATURES:

APP support Android & iOS

Weighing Reminder

Unlimited number of User

Auto recognize family Members

Auto LB/KG/ST recognition

Cloud-based data storage to ensure safety

Connect to Apple health kit/Google Fit/Fitbit and more

Password App Lock to ensure privacy

Calendar-based history review

Social sharing of measurement and moments



# BCA-140

CAPTAIN AMERICA  
WEIGHT SCALE



## APP FEATURES:

APP support Android & iOS

Weighing Reminder

Unlimited number of User

Auto recognize family Members

Auto LB/KG/ST recognition

Cloud-based data storage to ensure safety

Connect to Apple health kit/Google Fit/Fitbit and more

Password App Lock to ensure privacy

Calendar-based history review

Social sharing of measurement and moments





# BCR-140

SP THOR WEIGHT SCALE







# BCR-145

SPIDERMAN WEIGHT SCALE

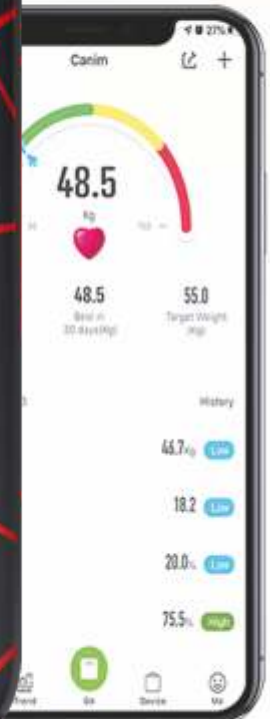



# MSB- 6S

## GYM SHAKER



### GYM SHAKER

Capacity	600ml
Material	Plastic
Color	Blue, Red, Clear
Storage	Yes





# WalkPad® Series

*"Make more people fall in love with healthy sports life"*

The WalkPad series is 90% space-saving than the traditional treadmill and can be easily folded and stored with the help of a double folding design and smooth-rolling wheels. It is a cardio choice for any home facility looking for ultra-thin walking treadmill space with remote control, exclusive sports app, foot speed sensing patent, modern unique design with child lock protection. It is of this series which is 100% Pre-installed with-in the single box, which is convenient and quick.

They are usually double foldable machines, and the walking platform uses a soft and comfortable EVA cushioning layer to protect the joints. It comes with a smooth layer of low friction coefficient, water-resistant, and anti-slip running belt.

It can be used to monitor the health status of the body using a heart rate sensor and the body fat detective system while some are featured with a weight scale to measure body weight also. The benefits of using Powermax Fitness Treadmills are they are easy to use; help you to track your work out progress, helps in losing weight faster than running outdoor, Allows to choose preset work-out programs, Improves heart health, improves muscles and calves toning, easy to fold and space-saving design as they are able to fit under the bed or beside the cupboard and wheels for easy transportation.



# WalkPad-5<sup>®</sup>

ULTRA-THIN WALKING FITNESS TREADMILL WITH REMOTE CONTROL



<b>Motor</b>	2.0HP Brushless DC Motor
<b>Max User Weight</b>	100KG
<b>Running Surface</b>	1200 x 400mm / 47.2 x 15.7inches
<b>Speed</b>	0.5 - 6km/hr
<b>Running Deck</b>	Foldable Running Deck
<b>Running Belt</b>	EVA cushioning layer, smooth layer with low friction coefficient, wear-resistant and anti-slip running belt.
<b>Display</b>	IML Technology - High-Brightness Light-Emitting LED Panel Eye-Catching and Dazzling
<b>Connectivity</b>	Bluetooth app for Android & iOS (KS Fit), Remote Control with Digital Display
<b>Foldable</b>	Double Fold
<b>Sports Mode</b>	Standby Mode / Manual Mode / Automatic Mode
<b>Applicable Age</b>	14 - 60 Years Old
<b>Warranty</b>	Lifetime Frame Warranty, 3 Year Motor Warranty and 1 Year Parts & Labor Warranty





# JogPad® Series

*"Make more people fall in love with healthy sports life"*

JogPad series is 90% space-saving than the traditional treadmill and can be easily folded and stored with the help of a Patented folding design and smooth-rolling wheels. The feature of putting the treadmill upright is the main unique selling point of the JogPad series. Its normal use is a treadmill, meeting the need for daily running. When the handrail is put down, it turns into a more space-saving walking pad, suitable for different use.

It is a cardio choice for any home facility looking for an ultra-thin walking treadmill space with remote control, exclusive sports app, foot speed sensing patent, modern unique design with child lock protection. It is of this series which is 100% Pre-installed with-in the single box, which is convenient and quick.

JogPad series is considered the best choice if you want to reap huge benefits with a little money and space. It is designed for domestic use only as the treadmill platform is a frequently used position, that is why we use high-density fiberboard to ensure its excellent quality; EVA cushioning layer with comfortable texture; smooth layer with low friction coefficient; wear-resistant and anti-slip running belt. The main feature that attracts is it comes with the motor less noise.

It can be used to monitor the health status of the body using a heart rate sensor and the body fat detective system while some are featured with a weight scale to measure body weight also. The benefits of using Powermax Fitness Treadmills are they are easy to use; help you to track your work out progress, helps in losing weight faster than running outdoor, Allows to choose preset work-out programs, Improves heart health, improves muscles and calves toning, easy to fold and space-saving design as they are able to fit under the bed or beside the cupboard and wheels for easy transportation.

## Touch Screen



*Trendy & Stylish*

# JogPad-2<sup>®</sup>

## TOUCH SCREEN DUAL DISPLAY TREADMILL



<b>Motor</b>	2.0HP DC Motor
<b>Max User Weight</b>	120KG
<b>Running Surface</b>	1100 x 400mm / 43.3 x 15.7inches
<b>Speed</b>	1.0 – 15.0km/hr
<b>Running Deck</b>	Foldable Running Deck
<b>Running Belt</b>	EVA cushioning layer, smooth layer with low friction coefficient, wear-resistant and anti-slip running belt.
<b>Display</b>	Touch Screen LED Display (Dual Display)
<b>Connectivity</b>	Remote Control and Bluetooth MP3 Speaker
<b>Foldable</b>	Compact Foldable
<b>Other Features</b>	Wheels for easy transportation
<b>Paint Quality</b>	Anti-bacterial powder Coat finish
<b>Warranty</b>	Lifetime Frame Warranty, 3 Year Motor Warranty and 1 Year Parts & Labor Warranty

### Fall in love with taking care of yourself!

Making your life easy with the all-new JogPad-2 Touch Screen Dual Display Treadmill with Bluetooth Speaker. Jogging on a treadmill with a top speed of 15 km per hour powered by a 2.5 Horse Power Peak DC motor makes this equipment very suitable for cardio. This JogPad-2 Touch Screen Dual Display Treadmill meets modern features as it has a dual display LED screen where parameters such as the time, speed, distance travelled, calories burnt, heart rate, etc, can be monitored. The benefits of running on this treadmill are quite a lot. A high amount of calorie burns, outside weather not hampering workouts, and technically very safe than running outside the house.





NEW WAY FOR WORKING  
SAY NO TO

## “THE SEATED”

PUTTING THE HANDRAIL DOWN, YOU WILL ENTER THE WALKING MODE. MOVE IT UNDER YOUR DESK, YOU WILL IMPROVE YOUR STATE OF WORKING.

# JogPad-5<sup>®</sup>

SMART WALK & JOG, DOUBLE FOLD TREADMILL WITH REMOTE CONTROL



<b>Motor</b>	2.0HP Brushless DC Motor
<b>Max User Weight</b>	110KG
<b>Running Surface</b>	1200 x 400mm / 47.2 x 15.7inches
<b>Speed</b>	0.5 - 10km/h (Max Speed Under Walking Pattern: 6km/h)
<b>Running Deck</b>	Foldable Running Deck
<b>Running Belt</b>	EVA cushioning layer, smooth layer with low friction coefficient, wear-resistant and anti-slip running belt.
<b>Display</b>	IML Technology - High-Brightness Light-Emitting LED Panel Eye-Catching and Dazzling
<b>Connectivity</b>	Bluetooth app for Android & iOS (KS Fit), Remote Control
<b>Foldable</b>	Double Fold
<b>Other Features</b>	Wheels for easy transportation
<b>Applicable Age</b>	14 - 60 Years Old
<b>Warranty</b>	Lifetime Frame Warranty, 3 Year Motor Warranty and 1 Year Parts & Labor Warranty



# UrbanTrek<sup>®</sup> Series

UrbanTrek™ Series is a family single upright tube, intelligent, Plug & Run treadmill. It is the cardio choice for any home facility looking for intuitive functionality, Space saving and modern unique design the whole machine of this series are 100% Pre-installed with-in the box, single button fast folding, convenient and quick.

They are featured with super wide treadmill and standing side rails with innovative ultra-low running platform without base frame design, having a height not more than 10cm from ground which makes running more comfortable and safe. The next generation suspension shock absorption system provides gradual force deflection, leading to soft landing to protect your knees and ankle effectively.

It can be used to monitor the health status of the body using heart rate sensor and the body fat detective system while some are featured with weight scale to measure body weight also. All machines of UrbanTrek™ Series have a quite, efficient, automatic noise reduction powerful motor. Additional features includes aeration fan for oxygen-full running, mobile app for Android & iOS to achieve cloud plan training, Step count function, Auto stop human detection and many more differentiating machines of UrbanTrek™ Series.



## TD-N1<sup>®</sup>

App for Android & iOS and Bluetooth Speakers



<b>Motor</b>	2.0HP DC Motor
<b>Max User Weight</b>	90KG
<b>Running Surface</b>	1210 x 410mm / 47.6 x 16.1inches
<b>Running Belt</b>	Diamond wave running belt
<b>Running Deck</b>	12mm thickness of Running board
<b>Rollers</b>	Precision-machined, steel crowned rollers keep belt centered and running smoothly to reduce noise and wear.
<b>Shock Absorption</b>	Spring shock absorption along with Double Layer Running Board
<b>Program</b>	12 Pre-set Programs with 3 Target Based Modes
<b>Speed</b>	1.0 - 12.0km/hr
<b>Display</b>	3 LED Display with 3D Smart Touch Keys - Time, Speed, Distance, Heart rate, Calories, Program
<b>Others Features</b>	Wheel for transportation, Foldable and Easy Installation, MP3, AUX & USB input and Bluetooth Speaker, App for Android & iOS.
<b>Installation</b>	100% Pre-installed, Just Plug & Run
<b>Warranty</b>	Lifetime Frame Warranty, 3 Year Motor Warranty and 1 Year Parts & Labor Warranty

**Product Description:** Searching a treadmill for the home gym. Here it is UrbanTrek™ TD-N1 treadmill, it helps to fight against Crabs, jogging on a treadmill with a top speed of 12km per hour powered by 2 Horse Power HiTorque DC motor. This UrbanTrek TD-N1 treadmill meets modern features along with Bluetooth connection to play music, unique running surface with side rail and more convenient for daily use.

## TD-M1<sup>®</sup>

Motorized Treadmill with Android & iOS Application

<b>Motor</b>	2.0HP DC Motor
<b>Max User Weight</b>	100KG
<b>Running Surface</b>	1210 x 410mm / 47.6 x 16.1inches
<b>Incline</b>	2 Level Manual Incline
<b>Running Belt</b>	Diamond wave running belt
<b>Rollers</b>	Precision-machined, steel crowned rollers keep belt centered and running smoothly to reduce noise and wear.
<b>Shock Absorption</b>	ComfortTech 6-Point Damping System with Double Layer Running Board
<b>Program</b>	12 Pre-set Programs with Heart rate sensors on handrail
<b>Speed</b>	1.0 - 14.0km/hr
<b>Display</b>	LCD Display - Time, Speed, Distance, Heart Rate, Calories, Program
<b>Others Features</b>	Wheel for transportation, Foldable, Bluetooth, MP3, AUX & USB input and Hi-Fi Speaker.
<b>Installation</b>	100% Pre-installed, Just Plug & Run
<b>Warranty</b>	Lifetime Frame Warranty, 3 Year Motor Warranty and 1 Year Parts & Labor Warranty



**Product Description:** Searching a treadmill for the home gym. Here it is UrbanTrek™ TD-M1 treadmill, it helps to fight against Crabs, jogging on a treadmill with a top speed of 14km per hour powered by 2.0 Horse Power HiTorque DC motor. This UrbanTrek TD-M1 treadmill meets modern features along with Bluetooth app to connect treadmill your mobile, unique running surface with side rail and more convenient for daily use.



## TD-M3<sup>®</sup>

### Motorized Treadmill with Bluetooth Music Function

<b>Motor</b>	2.0HP DC Motor
<b>Max User Weight</b>	100KG
<b>Running Surface</b>	1200 x 420mm / 47.2 x 16.5inches
<b>Incline</b>	3 Level Manual Incline
<b>Running Belt</b>	1.6mm Diamond wave running belt
<b>Rollers</b>	Precision-machined, steel crowned rollers keep belt centered and running smoothly to reduce noise and wear.
<b>Program</b>	15 Pre-set Programs (P1 - P15)
<b>Speed</b>	1.0 - 16.0km/hr
<b>Display</b>	LED Display - Time, Speed, Distance, Calories, Hand pulse, Body fat
<b>Others Features</b>	Heart rate sensors, Bluetooth App for Android & iOS, Bluetooth music, Foldable, iPad holder, USB input, Wheel for transportation
<b>Installation</b>	100% Pre-installed, Just Plug & Run
<b>Warranty</b>	Lifetime Frame Warranty, 3 Year Motor Warranty and 1 Year Parts & Labor Warranty



**Product Description:** Release your passion and fight for your youth with UrbanTrek TD-M3 multi-feature motorised treadmill. UrbanTrek TD-M3 is a space saving, smart treadmill with an arc frame, which resembles the racing running boats, with folding storage less than 0.5 square meters for aerobic brisk walking and comfortable jogging. The all new UrbanTrek TD-M3 treadmill has a top speed of 16km/hr powered by a 2.0 horse power HiTorque DC Motor and equipped with LED display console, 3d smart touch keys, mobile app connect via Bluetooth and many more. UrbanTrek TD-M3 treadmill features meet modern technology so your exercise is quick, hassle free, convenient and most importantly, fun.

## TD-M4<sup>®</sup>

Plug & Run Treadmill with Android & iOS App



<b>Motor</b>	2.0HP HiTorque™ LAMMER DC Motor
<b>Max User Weight</b>	100KG
<b>Running Surface</b>	1260 x 430mm / 49.2 x 6.9inches
<b>Running Belt</b>	3.2mm Diamond wave running belt
<b>Rollers</b>	Steel crowned rollers, precisely machined & duly dynamic balanced
<b>Shock Absorption</b>	6-Silkworm Rubber Balloon precision cushioning with widened Anti-slip side track for better shock absorption to reduce stress on your joints
<b>Program</b>	3 Pre-set Workout & 3 Target Based Modes
<b>Speed</b>	1.0 - 14.0km/hr
<b>Display</b>	3 LED Window Display - Time, Speed, Distance, Calories, Heart rate with sensor on console tube
<b>Others Features</b>	USB input, iPad holder, Vertical Stand, Semi-Auto Lubrication and Wheels for transportation
<b>Installation</b>	100% Pre-installed, Just Plug & Run
<b>Control</b>	Mobile App for Android & iOS via Bluetooth, PepplePress™ key for easy control.
<b>Warranty</b>	Lifetime Frame Warranty, 3 Year Motor Warranty and 1 Year Parts & Labor Warranty



**Product Description:** UrbanTrek™ TD-M4 is modern light weight design treadmill which subverts the traditional treadmill with folding storage less than 0.5 square meter for your ambition to lose weight. The new all UrbanTrek™ TD-M4 treadmill has a top speed of 14km/hr powered by a 2.0 Horse Power HiTorque™ DC LAMMER motor and equipped with 4 Rubber Balloon PowerFlex™ precision cushioning by which you can challenge yourself to take your fitness to the next level. UrbanTrek™ TD-M4 treadmill features meet modern technology so your exercise is quick, hassle free, convenient and most importantly, Fun!



## TD-M5®

### Installation Free Treadmill with Bluetooth Music



<b>Motor</b>	2.5HP Brushless DC Motor
<b>Max User Weight</b>	110KG
<b>Running Surface</b>	1300 x 500mm / 51.1 x 19.6inches
<b>Running Belt</b>	Diamond wave running belt
<b>Rollers</b>	Precision-machined, steel crowned rollers keep belt centred and running smoothly to reduce noise and wear.
<b>Shock Absorption</b>	AI Intelligent gasbag shock absorption system to reduce stress on your joints. (4 Level Adjustable Shock Absorption on Button)
<b>Program</b>	3 pre-set programs (HIIT fat reduction, Physical Training, Healthy Walk)
<b>Speed</b>	0.8 - 14.0km/hr
<b>Display</b>	LED Screen Display with Smart Touch Keys - Time, Speed, Distance, Heart rate, Calories
<b>Others Features</b>	Auto Lubrication, iPad Holder with long lasting Glue, Heart rate sensors on hand grip, Foldable, Bluetooth connection to play music, USB input, Speaker and Wheel for transportation.
<b>Installation</b>	100% Pre-installed, Just Plug & Run
<b>Warranty</b>	Lifetime Frame Warranty, 3 Year Motor Warranty and 1 Year Parts & Labor Warranty



**Product Description:** Searching a treadmill for the home gym. Here it is UrbanTrek™ TD-M5 treadmill, it helps to fight against Crabs, jogging on a treadmill with a top speed of 14km per hour powered by 2.5 Horse Power HiTorque DC motor. This UrbanTrek TD-M5 treadmill meets modern features along with Bluetooth connection to play music, unique running surface with side rail and more convenient for daily use. The benefits of running on this treadmill are vast; high-calorie burn, weather conditions won't impact your workout, you can monitor your workout intensity and it can be safer than running outdoors.

## TD-A1<sup>®</sup>

Motorized Treadmill with Android & iOS Application

<b>Motor</b>	2.0HP DC Motor
<b>Max User Weight</b>	100KG
<b>Running Surface</b>	1210 x 410mm / 47.6 x 16.1inches
<b>Incline</b>	15 Level Auto Incline
<b>Running Belt</b>	Diamond wave running belt
<b>Rollers</b>	Precision-machined, steel crowned rollers keep belt centered and running smoothly to reduce noise and wear.
<b>Shock Absorption</b>	ComfortTech 6-Point Damping System with Double Layer Running Board
<b>Program</b>	12 Pre-set Programs with Heart rate sensors on handrail
<b>Speed</b>	1.0 - 14.0km/hr
<b>Display</b>	LCD Display - Time, Speed, Distance, Heart Rate, Calories, Program
<b>Others Features</b>	Wheel for transportation, Foldable, Bluetooth, MP3, AUX & USB input and Hi-Fi Speaker.
<b>Installation</b>	100% Pre-installed, Just Plug & Run
<b>Warranty</b>	Lifetime Frame Warranty, 3 Year Motor Warranty and 1 Year Parts & Labor Warranty



### UrbanTrek TD-A1 - Motorized, 100% Pre-Installed, Modern Style Treadmill for Modern Family and Home

Searching a treadmill for the home gym. Here it is UrbanTrek™ TD-A1 treadmill, it helps to fight against Crabs, jogging on a treadmill with a top speed of 14km per hour powered by 2.0Horse Power HiTorque DC motor. This UrbanTrek TD-A1 treadmill meets modern features along with Bluetooth app to connect treadmill your mobile, unique running surface with the side rail, and more convenient for daily use. The benefits of running on this treadmill are vast; high-calorie burn, weather conditions won't impact your workout, you can monitor your workout intensity and it can be safer than running outdoors.

### Plug and Run - Zero-Installation

The UrbanTrek TD-A1 comes to you pre-assembled in the carton. This new design feature means it's ready for action - right out of the box! No fiddling with bolts or screws, Just Plug, and Run.

### Quality and Attraction

*We are responsible for making the treadmill attractive.*

*You are responsible for making yourself attractive.*

Simplified design yet beyond simplicity and the brick-shaped body design show the gentle temperament of the UrbanTrek TD-A1 treadmill. The ergonomic design makes the user feel comfortable and joy during the running time.

### High-level Configuration

UrbanTrek TD-A1 treadmill is equipped with MCU from ST Microelectronics, LCD drive clip, and the touching key clip from Taiwan Company, IGBT LCD drive clip from Fairchild Semiconductor in the US, static wire from BASF Germany and 2.0HP motor, which guarantees the quality of the hardware.



## TD-A3<sup>®</sup>

### Premium Series Treadmill with Android & iOS App









<b>Motor</b>	2.5HP DC Motor
<b>Max User Weight</b>	120KG
<b>Running Surface</b>	1300 x 480mm / 51.1 x 18.9inches
<b>Incline</b>	12 Level Auto Incline
<b>Running Belt</b>	Diamond wave running belt
<b>Rollers</b>	Precision-machined, steel crowned rollers keep belt centred and running smoothly to reduce noise and wear.
<b>Shock Absorption</b>	6 Cylinder PowerFlex™ Adaptive Cushioning System (PACS) to reduce impact up to 25% compared to running on road.
<b>Program</b>	8 Pre-set Programs, 3 User Defined Program & 3 Target Based Modes
<b>Speed</b>	1.0 - 14.0km/hr
<b>Display</b>	IMD Technology 135° Edge Display - Time, Speed, Distance, Pulse, Incline and Calories
<b>Others Features</b>	Bluetooth App for Android & iOS, Step function, iPad Holder, Auto Standby Power Saving Mode, Easy Foldable, Running Ambience Light and 4 Wheels 360 degree rotation
<b>Installation</b>	100% Pre-installed, Just Plug & Run
<b>Warranty</b>	Lifetime Frame Warranty, 4 Year Motor Warranty and 1 Year Parts & Labor Warranty



**Product Description:** If you are looking for reliable and durable treadmills that also have feature of a folding frame, than this model is great choice. UrbanTrek™ TD-A3 Premium Model treadmill introduces modern technology treadmill that concise with 2.5 HP DC Sunken motor along with the top speed of 14 km per hour. It is easily transportable from one place to another. When we talk about a gym, treadmill plays the most vital role among all the mean machines you should have in your arena. UrbanTrek™ TD-A3 gives major goals.

## EcoTrek Series Manual Treadmills

The PowerMax introduces 'EcoTrek Series' manual treadmill and it is considered as an ultimate tool for people who are desperately seeking options for becoming fit and healthy. These treadmills are considered as the best choice if you want to reap huge benefits with your little money and space. The Manual treadmill has multi-functions with high-quality frames, space-saving design and helps in burning calories faster than running outside. It is designed for domestic use and the machine fulfils all keys of the needs that are required in the muscle group to improve lower body strength and endurance such as quadriceps, calves, and hamstrings. Treadmill offers various Programmed workouts that vary the speed and incline to focus on specific goals and to improve cardiovascular health.

<b>T</b> <sup>®</sup>	→ Treadmill		<b>T</b> <sup>®</sup>	→ Treadmill		<b>T</b> <sup>®</sup>	→ Treadmill	
<b>D</b>	→ DC Motor		<b>D</b>	→ DC Motor		<b>A</b>	→ AC Motor	
<b>A</b>	→ Auto incline		<b>M</b>	→ Manual incline		<b>C</b>	→ Commercial	

## MaxTrek Series DC & AC Motorised Treadmills

The MaxTrek Series are designed simple and sturdy for the combined set of Domestic use as well as Semi-Commercial use. This series offers all kind of treadmills starting from basic models with basic features to high-end model with advanced features. This treadmill help to burn excess amount of calories and improves cardiovascular health more effectively than running out-door. This series are further classified into three different segment. TDM Treadmill with DC Motor and Manual Incline, TDA Treadmill with DC Motor and Auto- Incline and TAC Treadmill with Auto-Incline for Semi-Commercial Use.

This series provides ample of features for the one who is really into losing weight, getting in to shape and fit and fine. The MaxTrek Treadmills delivers 90% Pre-installed and are packed in to boxes. They also delivers Heart rate sensor, Detects Hand Pulse, lifetime frame warranty, large color touch screen display, mobile app via Bluetooth, USB option, Wi-Fi, Hi-Fi speakers, Best motors and incline, Wide running surface Belt .

The benefits of using Powermax Fitness Treadmills are they are easy to use; help you to track your work out progress, Helps in losing weight faster than running out door, Allows to choose preset work-out programs, Improves heart health, improves in muscles and calves toning, easy to fold and space saving design as they are able to fit under the bed or beside the cupboard and wheels for easy transportation.



## MFT-410<sup>®</sup>

### 4 IN 1 Multi-functional Manual Treadmill



4 in 1 - Jogger, Stepper, twister, Push up bar	
High quality and Strong Steel Frame	
<b>Incline</b>	3 Level Manual Incline
<b>Running Surface</b>	1160 X 335mm / 45.6 X 13.1inches
<b>Running Belt</b>	Bubble Etched Running Belt
<b>Display</b>	Five window LCD monitor showing Calories, Time, Speed, Distance & Heart rate
<b>Program</b>	4 Target based modes
<b>Speed</b>	1.0 - 14.0km/hr
<b>Others Features</b>	Wheel for transportation
<b>Max User Weight</b>	120KG
<b>Warranty</b>	Lifetime Frame Warranty, and 1 Year Parts & Labor Warranty



## TDM-97<sup>®</sup>

### Motorised Treadmill with iPad holder

<b>Motor</b>	1.75HP DC Motor
<b>Max User Weight</b>	100KG
<b>Running Surface</b>	1100 x 400 mm / 43.3 x 15.7 inches
<b>Running Belt</b>	Multi-ply polyester satin weave with a PVC non-slip surface of 1.8 mm thickness
<b>Rollers</b>	Precision-machined, steel crowned rollers keep belt centered and running smoothly to reduce noise and wear
<b>Shock Absorption</b>	Cast steel resistance & 6-ply running board damping system to reduce stress on your joints
<b>Program</b>	12 Pre-set workout & 3 target based modes
<b>Speed</b>	1.0 - 10.0km/hr
<b>Display</b>	14cm LED Display - Time, Speed, Distance, Calories & Heart rate
<b>Others Features</b>	Speaker, AUX input with volume keys, Wheels for transportation, Foldable with manual lock and iPad holder
<b>Warranty</b>	Lifetime Frame Warranty, 3 Year Motor Warranty and 1 Year Parts & Labor Warranty

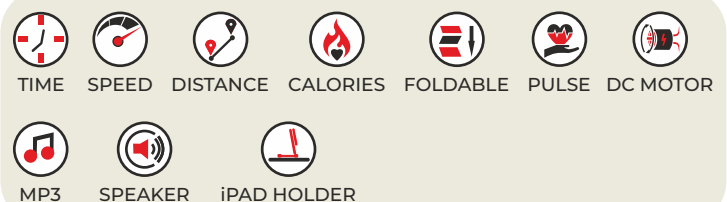

## TDM-98®

### Motorised Treadmill with Heart Rate Sensors



<b>Motor</b>	1.75HP DC Motor
<b>Max User Weight</b>	100KG
<b>Running Surface</b>	1100 x 400mm / 43.3 x 15.7 inches
<b>Running Belt</b>	Multi-ply polyester satin weave with a PVC non-slip surface of 1.8 mm thickness
<b>Rollers</b>	Precision-machined, steel crowned rollers keep belt centered and running smoothly to reduce noise and wear
<b>Shock Absorption</b>	Cast steel resistance & 6-ply running board damping system to reduce stress on your joints
<b>Program</b>	12 Pre-set workout & 3 target based modes
<b>Speed</b>	1.0 - 10.0km/hr
<b>Foldable</b>	Foldable with Manual Lock
<b>Display</b>	14cm LED Display - Time, Speed, Distance, Calories & Heart rate
<b>Others Features</b>	Wheels for transportation and Easy to install, AUX & USB input and Speaker with volume controller
<b>Warranty</b>	Lifetime Frame Warranty, 3 Year Motor Warranty and 1 Year Parts & Labor Warranty

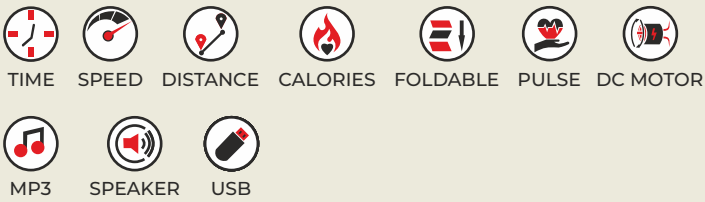

## TDM-99®

### Motorised Treadmill with Ropes and Twister

<b>Motor</b>	2.0HP DC Motor
<b>Max User Weight</b>	110KG
<b>Incline</b>	3 Level Manual Incline
<b>Running Surface</b>	1150 x 405mm / 45.2 x 15.9 inches
<b>Running Belt</b>	Multi-ply polyester satin weave with a PVC non-slip surface of 1.8 mm thickness
<b>Rollers</b>	Precision-machined, steel crowned rollers keep belt centered and running smoothly to reduce noise and wear
<b>Shock Absorption</b>	Rubber cushion shock absorption equipped with double layer running board to reduce stress on your joints.
<b>Program</b>	12 Pre-set workout & 3 target based modes
<b>Speed</b>	1.0 - 14.0km/hr speed select hot keys
<b>Display</b>	Blue LCD Display - Time, Speed, Distance, Calories & Heart rate
<b>Others Features</b>	AUX input, iPad holder, Foldable, Easy to install and Wheels for transportation
<b>Multifunction</b>	2pcs Resistance Ropes and 1 Twister
<b>Warranty</b>	Lifetime Frame Warranty, 3 Year Motor Warranty and 1 Year Parts & Labor Warranty

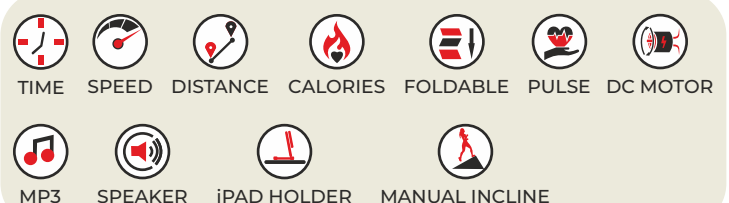



## TDM-99S®

### Motorised Treadmill with LED Display



<b>Motor</b>	12HP DC Motor
<b>Max User Weight</b>	110KG
<b>Incline</b>	3 Level Manual Incline
<b>Running Surface</b>	1150 x 405mm / 45.2 x 15.9inches
<b>Running Belt</b>	Multi-ply polyester satin weave with a PVC non-slip surface of 1.8 mm thickness
<b>Rollers</b>	Precision-machined, steel crowned rollers keep belt centered and running smoothly to reduce noise and wear
<b>Shock Absorption</b>	Rubber cushion shock absorption equipped with double layer running board to reduce stress on your joints.
<b>Program</b>	12 Pre-set workout & 3 target based modes
<b>Speed</b>	1.0 - 14.0km/hr
<b>Display</b>	LED Window Display - Time, Speed, Distance, Calories & Heart rate
<b>Others Features</b>	USB, AUX input, iPad holder, Foldable, Easy to install and Wheels for transportation
<b>Warranty</b>	Lifetime Frame Warranty, 3 Year Motor Warranty and 1 Year Parts & Labor Warranty



## TDM-100M®

### Multi-function Treadmill with Semi-Auto Lubrication

<b>Motor</b>	2.0HP DC Motor
<b>Max User Weight</b>	105KG
<b>Incline</b>	6 Level Manual Incline
<b>Running Surface</b>	1260 x 430mm / 49.6 x 16.9inches
<b>Running Belt</b>	Multi-ply polyester satin weave with a PVC non-slip surface of 1.8 mm thickness
<b>Rollers</b>	Precision-machined, steel crowned rollers keep belt centered and running smoothly to reduce noise and wear
<b>Shock Absorption</b>	Dual spring shock absorption with double layer running board for better shock absorption to reduce stress on your joints.
<b>Program</b>	12 Pre-set workout & 3 target based modes
<b>Speed</b>	0.8 - 14.8km/hr
<b>Display</b>	12.7cm LED Display - Time, Speed, Distance, Calories & Heart rate
<b>Others Features</b>	AUX input, Semi-Auto Lubrication, Heavy duty running belt, Foldable, Easy to install and Wheels for transportation
<b>Multifunction</b>	Massager & Sit-ups
<b>Warranty</b>	Lifetime Frame Warranty, 3 Year Motor Warranty and 1 Year Parts & Labor Warranty



## TDM-100S®

### Auto Lubrication Treadmill with Jumping Wheels



<b>Motor</b>	1.5HP DC Motor
<b>Max User Weight</b>	110KG
<b>Incline</b>	3 Level Manual Incline
<b>Running Surface</b>	1150 x 420mm / 45.2 x 16.5inches
<b>Running Belt</b>	Multi-ply polyester satin weave with a PVC non-slip surface of 1.8 mm thickness
<b>Rollers</b>	Precision-machined, steel crowned rollers keep belt centered and running smoothly to reduce noise and wear
<b>Shock Absorption</b>	Six big shocks absorbing springs double layer running board to reduce stress on your joints.
<b>Program</b>	12 Pre-set workout & 3 target based modes
<b>Speed</b>	0.8 - 14.8km/hr
<b>Display</b>	LED Window Display - Time, Speed, Distance, Calories & Heart rate
<b>BMI</b>	It helps to know whether your fat is healthy or not
<b>Others Features</b>	AUX & USB input, Speaker, iPad holder, Bottle holder, Foldable, Auto Lubrication, Easy installation, Spring Jumping wheels and Wheel for transportation
<b>Warranty</b>	Lifetime Frame Warranty, 3 Year Motor Warranty and 1 Year Parts & Labor Warranty



## TDM-101®

### Motorized Treadmill with MP3 & iPad holder

<b>Motor</b>	2.0HP DC Motor
<b>Max User Weight</b>	100KG
<b>Running Surface</b>	1200 x 420mm / 47.2 x 16.5inches
<b>Running Belt</b>	Diamond wave running belt
<b>Rollers</b>	Precision-machined, steel crowned rollers keep belt centered and running smoothly to reduce noise and wear
<b>Program</b>	12 Pre-set workout & 3 target based modes
<b>Speed</b>	0.8 - 14.8km/hr
<b>Display</b>	LCD Display - Time, Speed, Distance, Calories, Program
<b>Others Features</b>	AUX input, Speaker, iPad holder, Bottle & Accessories holder, Foldable, Easy Installation and Wheel for transportation
<b>Warranty</b>	Lifetime Frame Warranty, 3 Year Motor Warranty and 1 Year Parts & Labor Warranty

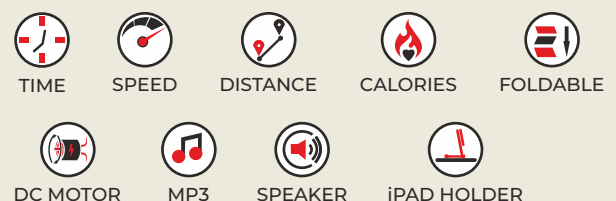



## TDM-105S®

### Semi-Auto Lubrication Treadmill



<b>Motor</b>	2.0HP DC Motor
<b>Max User Weight</b>	115KG
<b>Incline</b>	3 Level Manual Incline
<b>Running Surface</b>	1260 x 420mm / 49.6 x 16.5inches
<b>Running Belt</b>	Multi-ply polyester satin weave with a PVC non-slip surface of 1.8 mm thickness
<b>Rollers</b>	Precision-machined, steel crowned rollers keep belt centered and running smoothly to reduce noise and wear
<b>Shock Absorption</b>	6 level shock absorption system with variable-durometer elastomer cushions for better shock absorption to reduce stress on your Joints
<b>Program</b>	12 Pre-set workout & 3 target based modes
<b>Speed</b>	1.0 - 14.0km/hr
<b>Display</b>	Blue Back Light LCD Display - Time, Speed, Distance, Calories & Heart rate
<b>BMI</b>	It helps to know whether your fat is healthy or not
<b>Others Features</b>	Semi Auto Lubrication, Foldable, Easy to Install, iPad holder, AUX, USB input, Speaker with Music Control keys and Wheels for transportation
<b>Warranty</b>	Lifetime Frame Warranty, 3 Year Motor Warranty and 1 Year Parts & Labor Warranty



## TDM-110®

### 7.2" Large Vivid Color Display Motorised Treadmill



<b>Motor</b>	2.0HP DC GREEN Efficient Motor
<b>Max User Weight</b>	110KG
<b>Incline</b>	4 Level Manual Incline
<b>Running Surface</b>	1250 x 425mm / 49.2 x 16.7inches
<b>Running Belt</b>	Multi-ply urethane coated high conductivity polyester satin weave with a PVC non-slip surface of 1.8 mm thickness.
<b>Rollers</b>	Precision-machined, steel crowned rollers keep belt centered and running smoothly to reduce noise and wear
<b>Shock Absorption</b>	6 Level Damping System with variable Durometer Elastomer cushions for better shock absorption to reduce stress on your joints.
<b>Program</b>	8 Pre-set workout & 3 target based modes
<b>Speed</b>	1.0 - 16.0km/hr
<b>Display</b>	7.2" Large LCD vivid color Display with 400m track UI - Time, Speed, Distance, Calories, Heart rate
<b>Others Features</b>	Foldable, iPad holder, AUX, USB input, Headphone, Hi-Fi Speaker with Music control keys, Equalizer and Wheels for transportation
<b>Warranty</b>	Lifetime Frame Warranty, 3 Year Motor Warranty and 1 Year Parts & Labor Warranty

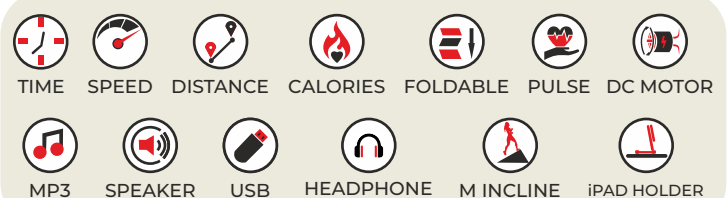

## TDM-111®

### Semi-Auto Lubrication Treadmill with Smart Run



<b>Motor</b>	2.0HP DC Motor
<b>Max User Weight</b>	115KG
<b>Incline</b>	3 - 5 Level Manual Incline
<b>Running Surface</b>	1260 x 420mm / 49.6 x 16.5inches
<b>Running Belt</b>	Multi-ply polyester satin weave with a PVC non-slip surface of 1.8 mm thickness
<b>Rollers</b>	Precision-machined, steel crowned rollers keep belt centered and running smoothly to reduce noise and wear
<b>Shock Absorption</b>	Dual spring shock absorption equipped with ComfortTech™ - 6 point commercial grade damping system.
<b>Program</b>	12 Pre-set workout & 3 target based modes
<b>Speed</b>	0.8 - 14.0km/hr with Fast Key on Handrail
<b>Display</b>	14cm LCD Display - Time, Speed, Distance, Calories, Heart rate, Programs
<b>Others Features</b>	Smart Run Function, iPad Holder, Bottle & Accessories Holder, AUX & USB input, Speaker, Foldable, Semi-Auto Lubrication, Easy Installation and Wheel for transportation
<b>Warranty</b>	Lifetime Frame Warranty, 3 Year Motor Warranty and 1 Year Parts & Labor Warranty



## TDM-125®

### Semi-Auto Lubricating Treadmill with Android & iOS App

<b>Motor</b>	2.0HP DC GREEN Efficient Motor
<b>Max User Weight</b>	115KG
<b>Incline</b>	3 Level Manual Incline
<b>Running Surface</b>	1230 x 420mm / 48.4 x 16.5inches
<b>Running Belt</b>	Multi-ply urethane coated high conductivity polyester satin weave with a PVC non-slip surface of 1.8 mm thickness.
<b>Rollers</b>	Precision-machined, steel crowned rollers keep belt centered and running smoothly to reduce noise and wear
<b>Shock Absorption</b>	Dual spring shock absorption system with ComfortTech™ - 6 point commercial grade damping system to reduce stress on your joints.
<b>Program</b>	12 Pre-set workout & 3 target based modes
<b>Speed</b>	1.0 - 14.0km/hr
<b>Display</b>	14cm LCD Display - Time, Speed, Distance, Calories, Pulse, BMI & Heart Beat
<b>Others Features</b>	Heart rate sensor on crossbar handle, Semi-Auto Lubricating, Foldable, AUX input, Speaker with Music control keys, Easy to install and Wheels for transportation
<b>BMI</b>	It helps to know whether your fat is healthy or not.
<b>Warranty</b>	Lifetime Frame Warranty, 3 Year Motor Warranty and 1 Year Parts & Labor Warranty

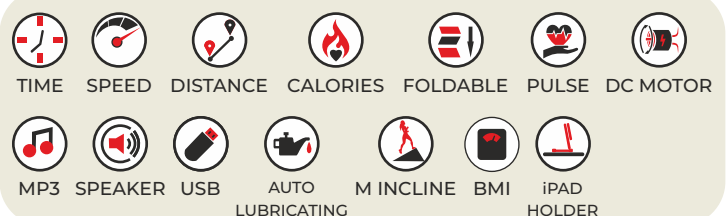



## TDA-100®

### Semi Auto Lubrication Treadmill with Auto Incline



<b>Motor</b>	2.0HP DC Motor
<b>Max User Weight</b>	110KG
<b>Incline</b>	15 Level Auto Incline
<b>Running Surface</b>	1260 x 430mm / 49.6 x 16.9inches
<b>Running Belt</b>	Grass Texture Running Belt
<b>Rollers</b>	Precision-machined, steel crowned rollers keep belt centered and running smoothly to reduce noise and wear
<b>Shock Absorption</b>	Dual spring shock absorption with double layer running board for better shock absorption to reduce stress on your joints.
<b>Program</b>	12 Pre-set workout & 3 target based modes
<b>Speed</b>	0.8 - 14.8km/hr
<b>Display</b>	12.7cm LED Display - Time, Speed, Distance, Calories & Heart rate
<b>Others Features</b>	AUX input, Semi-Auto Lubrication, Heavy duty running belt, Foldable, Easy to install and Wheels for transportation
<b>Warranty</b>	Lifetime Frame Warranty, 3 Year Motor Warranty and 1 Year Parts & Labor Warranty

## TDA-111®

### Semi-Auto Lubrication Treadmill with Smart Run

<b>Motor</b>	2.0HP DC Motor
<b>Max User Weight</b>	115KG
<b>Incline</b>	15 Level Auto Incline
<b>Running Surface</b>	1260 x 420mm / 49.6 x 16.5inches
<b>Running Belt</b>	Multi-ply polyester satin weave with a PVC non-slip surface of 1.8 mm thickness
<b>Rollers</b>	Precision-machined, steel crowned rollers keep belt centered and running smoothly to reduce noise and wear
<b>Shock Absorption</b>	Dual spring shock absorption equipped with ComfortTech™ - 6 point commercial grade damping system.
<b>Program</b>	12 Pre-set workout & 3 target based modes
<b>Speed</b>	0.8 - 14.0km/hr with Fast Key on Handrail
<b>Display</b>	14cm LCD Display - Time, Speed, Distance, Calories, Heart rate, Programs
<b>Others Features</b>	Smart Run Function, iPad Holder, Bottle & Accessories Holder, AUX & USB input, Speaker, Foldable, Semi-Auto Lubrication, Easy Installation and Wheel for transportation
<b>Warranty</b>	Lifetime Frame Warranty, 3 Year Motor Warranty and 1 Year Parts & Labor Warranty

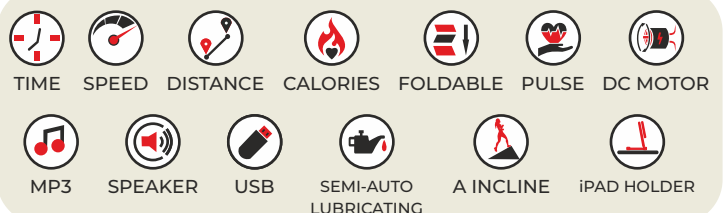

## TDA-125<sup>®</sup>

### Motorised Treadmill with Auto Lubrication



<b>Motor</b>	2.0HP DC GREEN Efficient Motor
<b>Max User Weight</b>	115KG
<b>Incline</b>	18 Level Auto Incline
<b>Running Surface</b>	1260 x 420mm / 49.6 x 16.5inches
<b>Running Belt</b>	Multi-ply urethane coated high conductivity polyester satin weave with a PVC non-slip surface of 1.8 mm thickness.
<b>Rollers</b>	Steel crowned rollers, precisely machined & duly dynamic balanced
<b>Shock Absorption</b>	Dual spring shock absorption system with ComfortTech™ - 6 point commercial grade damping system to reduce stress on your joints.
<b>Program</b>	12 Pre-set workout & 3 target based modes
<b>Speed</b>	0.8 - 16.0km/hr Speed select hot keys
<b>Display</b>	5.5" Bright Blue LCD Display - Time, Speed, Distance, Calories & Heart rate
<b>Others Features</b>	Smart Run Function, Pulse Sensors, Auto Lubrication, Foldable, Easy to Install, AUX & USB input, iPad holder, Speaker with Music control keys and Wheels for transportation
<b>BMI</b>	It helps to know whether your fat is healthy or not.
<b>Warranty</b>	Lifetime Frame Warranty, 3 Year Motor Warranty and 1 Year Parts & Labor Warranty



## TDA-150<sup>®</sup>

### Semi-Auto Lubricating Motorised Treadmill

<b>Motor</b>	2.5HP DC GREEN Efficient Motor
<b>Max User Weight</b>	120KG
<b>Incline</b>	18 Level Auto Incline
<b>Running Surface</b>	1260 x 450mm / 49.6 x 17.7inches
<b>Running Belt</b>	Multi-ply urethane coated high conductivity polyester satin weave with a PVC non-slip surface of 1.8 mm thickness.
<b>Rollers</b>	Precision-machined, steel crowned rollers keep belt centered and running smoothly to reduce noise and wear
<b>Shock Absorption</b>	ComfortTech 6-Point Commercial Grade Damping System with dual spring suspension
<b>Program</b>	12 Pre-set workout & 3 target based modes
<b>Speed</b>	1.0 - 18.0km/hr
<b>Display</b>	5.5" LCD Display - Time, Speed, Distance, Incline, Calories, Body fat & Heart Beat
<b>Others Features</b>	Smart Run Function, AUX & USB input, Hi-Fi Speaker, Auto Lubrication, Foldable, Easy to Install and Wheels for transportation
<b>BMI</b>	It helps to know whether your fat is healthy or not.
<b>Warranty</b>	Lifetime Frame Warranty, 3 Year Motor Warranty and 1 Year Parts & Labor Warranty

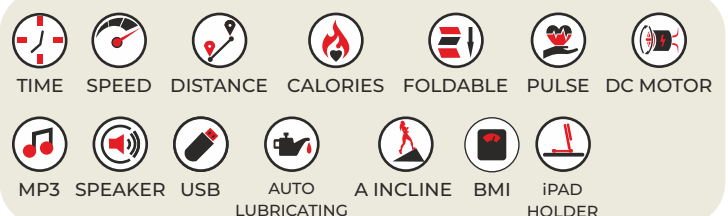



## TDA-230<sup>®</sup>

### Semi-Auto Lubricating Motorised Treadmill



<b>Motor</b>	2.0HP DC GREEN Efficient Motor
<b>Max User Weight</b>	115KG
<b>Incline</b>	15 Level Auto Incline
<b>Running Surface</b>	1260 x 420mm / 49.6 x 16.5inches
<b>Running Belt</b>	Multi-ply urethane coated high conductivity polyester satin weave with a PVC non-slip surface of 1.8 mm thickness.
<b>Rollers</b>	Precision-machined, steel crowned rollers keep belt centered and running smoothly to reduce noise and wear
<b>Shock Absorption</b>	ComfortTech 6-Point Commercial Grade Damping System with dual spring suspension
<b>Program</b>	12 Pre-set workout & 3 target based modes
<b>Speed</b>	1.0 - 14.0km/hr speed select hot keys
<b>Display</b>	5.5" Bright Blue LCD Display - Time, Speed, Distance, Incline, Calories & Heart rate
<b>Others Features</b>	Wheels for transportation, Auto Lubrication, Foldable and Easy to install, iPad holder, AUX & USB input & Music control keys
<b>BMI</b>	It helps to know whether your fat is healthy or not.
<b>Warranty</b>	Lifetime Frame Warranty, 3 Year Motor Warranty and 1 Year Parts & Labor Warranty



## TDA-230M<sup>®</sup>

### Multifunction Treadmill with Semi-Auto Lubrication

<b>Motor</b>	2.0HP DC GREEN Efficient Motor
<b>Max User Weight</b>	115KG
<b>Incline</b>	15 Level Auto Incline
<b>Running Surface</b>	1260 x 420mm / 49.6 x 16.5inches
<b>Running Belt</b>	Multi-ply urethane coated high conductivity polyester satin weave with a PVC non-slip surface of 1.8 mm thickness.
<b>Rollers</b>	Precision-machined, steel crowned rollers keep belt centered and running smoothly to reduce noise and wear
<b>Shock Absorption</b>	ComfortTech 6-Point Commercial Grade Damping System with dual spring suspension
<b>Program</b>	12 Pre-set workout & 3 target based modes
<b>Speed</b>	1.0 - 14.0km/hr speed select hot keys
<b>Display</b>	5.5" Bright Blue LCD Display - Time, Speed, Distance, Incline, Calories & Heart rate
<b>Others Features</b>	Wheels for transportation, Auto Lubrication, Foldable and Easy to install, iPad holder, AUX & USB input & Music control keys
<b>BMI</b>	It helps to know whether your fat is healthy or not.
<b>Multifunction</b>	Massager, Sit-ups, Dumbbells and Twister
<b>Warranty</b>	Lifetime Frame Warranty, 3 Year Motor Warranty and 1 Year Parts & Labor Warranty

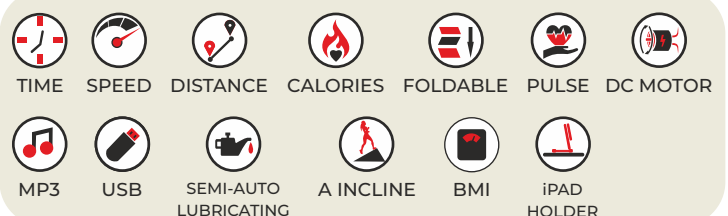

## TDA-255<sup>®</sup>

### Multifunction Treadmill with Auto Lubrication



<b>Motor</b>	2.5HP DC Motor
<b>Max User Weight</b>	125KG
<b>Incline</b>	15 Level Auto Incline
<b>Running Surface</b>	1300 x 450mm / 51.1 x 17.7inches
<b>Running Belt</b>	3.2mm Diamond wave running belt
<b>Rollers</b>	Precision-machined, steel crowned rollers keep belt centered and running smoothly to reduce noise and wear
<b>Shock Absorption</b>	8 Drum Octo-Flex Rubber Cushion with ComfortTech™ 6-Point Commercial Grade Damping System
<b>Program</b>	12 Pre-set workout & 3 target based modes
<b>Speed</b>	1.0 - 15.8km/hr speed select hot keys
<b>Display</b>	12.7cm LCD Display - Time, Speed, Distance, Incline, Calories & Heart rate
<b>Others Features</b>	Wheels for transportation, Auto Lubrication, Foldable and Easy to install, iPad holder, AUX & USB input, Speaker with Music control keys
<b>BMI</b>	It helps to know whether your fat is healthy or not.
<b>Multifunction</b>	Massager and Sit-ups
<b>Warranty</b>	Lifetime Frame Warranty, 3 Year Motor Warranty and 1 Year Parts & Labor Warranty



## TDA-350<sup>®</sup>

### Motorised Treadmill with 400m Track UI

<b>Motor</b>	3.0HP DC Motor
<b>Max User Weight</b>	130KG
<b>Incline</b>	18 Level Auto Incline
<b>Running Surface</b>	1360 X 480mm / 53.5 X 18.8inches
<b>Running Belt</b>	3.2mm Diamond strip Anti-static running belt
<b>Rollers</b>	Precision-machined, steel crowned rollers keep belt centered and running smoothly to reduce noise and wear
<b>Shock Absorption</b>	Octo flexi rubber cushion with Double Layer Running Board for better shock absorption to reduce stress on your joints
<b>Program</b>	12 Pre-set workout & 3 Target based modes
<b>Speed</b>	1.0 - 18.0km/hr Speed select hot keys
<b>Display</b>	17.9cm Blue LCD display with 400m track UI
<b>Others Features</b>	AUX, USB for charging, Cooling Fan, iPad holder, Hi-Fi speaker, Bluetooth for Android & iOS App, Foldable and Easy to install and Wheels for transportation
<b>BMI</b>	It helps to know whether your fat is healthy or not.
<b>Warranty</b>	Lifetime Frame Warranty, 3 Year Motor Warranty and 1 Year Parts & Labor Warranty





## TDA-360®

### 10.1inch HD Display Multifunction Motorized Treadmill

<b>Motor</b>	3.0HP DC Motor
<b>Max User Weight</b>	140KG
<b>Incline</b>	15 Level Auto Incline
<b>Running Surface</b>	1350 X 480mm / 53.1 X 18.8 inches
<b>Running Belt</b>	3.2 Diamond wave running belt
<b>Rollers</b>	Precision-machined, steel crowned rollers keep belt centered and running smoothly to reduce noise and wear
<b>Shock Absorption</b>	Dual spring shock absorption system with ComfortTech™ - 6-point commercial grade damping system to reduce stress on your joints.
<b>Program</b>	12 Pre-set Programs & 3 Target-based modes
<b>Speed</b>	1.0-18km/hr with speed buttons on handrail
<b>Display</b>	25.7cm Touch Screen - Time, Speed, Distance, Calories, Heart rate and Fat Measure
<b>Others Features</b>	AUX & USB input, Hi-Fi Speaker, Foldable (HSS), Auto Lubrication, Easy Installation and Wheel for transportation
<b>Multifunction</b>	Massager, Sit-ups and Dumbbells
<b>Warranty</b>	Lifetime Frame Warranty, 3 Year Motor Warranty and 1 Year Parts & Labor Warranty



## TDA-360®

### 15.6inch HD Display Motorized Treadmill with Auto Incline

<b>Motor</b>	3.0HP DC Motor
<b>Max User Weight</b>	140KG
<b>Incline</b>	15 Level Auto Incline
<b>Running Surface</b>	1350 X 480mm / 53.1 X 18.8 inches
<b>Running Belt</b>	3.2 Diamond wave running belt
<b>Rollers</b>	Precision-machined, steel crowned rollers keep belt centered and running smoothly to reduce noise and wear
<b>Shock Absorption</b>	Dual spring shock absorption system with ComfortTech™ - 6-point commercial grade damping system to reduce stress on your joints.
<b>Program</b>	12 Pre-set Programs & 3 Target-based modes
<b>Speed</b>	1.0-18km/hr with speed buttons on handrail
<b>Display</b>	39.6cm Touch Screen - Time, Speed, Distance, Calories, Heart rate and Fat Measure
<b>Others Features</b>	iPad Holder, AUX & USB input, Hi-Fi Speaker, Foldable (HSS), Auto Lubrication, Easy Installation and Wheel for transportation
<b>Multifunction</b>	Massager, Sit-ups and Dumbbells
<b>Warranty</b>	Lifetime Frame Warranty, 3 Year Motor Warranty and 1 Year Parts & Labor Warranty

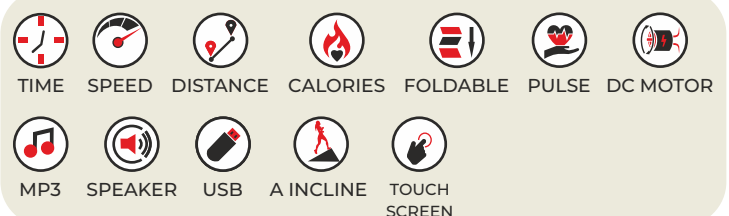

## TDA-500®

### Semi Auto Lubricating Treadmill with 3D Smart Touch keys



<b>Motor</b>	4.0HP DC Motor
<b>Max User Weight</b>	150KG
<b>Incline</b>	15 Level Auto Incline
<b>Running Surface</b>	1400 x 500mm / 55.1 x 19.6inches
<b>Running Belt</b>	Diamond wave running belt with widened Anti-slip side track
<b>Rollers</b>	Precision-machined, steel crowned rollers keep belt centered and running smoothly to reduce noise and wear
<b>Shock Absorption</b>	6 Cylinder PowerFlex™ Adaptive Cushioning System (PACS) to reduce impact up to 25% compared to running on road.
<b>Program</b>	12 Pre-set workout & 3 target based modes
<b>Speed</b>	0.8 - 20.0km/hr
<b>Display</b>	Red LED Display with 400m Track LED Indicator - Time, Speed, Distance, Calories, Heart rate, Incline
<b>Others Features</b>	Heart Rate sensors, 360° rotating Wheels, MP3, USB, Semi-Auto Lubrication, Hi-Fi Speaker, iPad holder, HSS System and wheels for transportation.
<b>Warranty</b>	Lifetime Frame Warranty, 3 Year Motor Warranty and 1 Year Parts & Labor Warranty



## TDA-550®

### Motorised Treadmill with 8" TFT Screen

<b>Motor</b>	4.0HP DC Motor
<b>Max User Weight</b>	135KG
<b>Incline</b>	20 Level Auto Incline
<b>Running Surface</b>	1480 X 520mm / 58.2 X 20.4inches
<b>Running Belt</b>	3.5mm Diamond strip Anti- static running belt
<b>Rollers</b>	Precision-machined, steel crowned rollers keep belt centered and running smoothly to reduce noise and wear
<b>Run Board</b>	18 mm low maintenance pre- waxed phenolic coated both sides
<b>Shock Absorption</b>	Arch shox system with Double Layer Running Board for better shock absorption to reduce stress on your joints
<b>Program</b>	12 Pre-set workout & 3 Target based modes
<b>Speed</b>	1.0 - 18.0km/hr Speed select hot keys
<b>Display</b>	20.3cm Blue LCD display - Time, Speed, Distance, Incline, Calories & Pulse Sensor
<b>Others Features</b>	Cooling Fan, iPad holder, Bluetooth for Android & iOS App, AUX, USB for charging & Hi-Fi Speaker, Foldable and Wheels for transportation
<b>BMI</b>	It helps to know whether your fat is healthy or not.
<b>Warranty</b>	Lifetime Frame Warranty, 3 Year Motor Warranty and 1 Year Parts & Labor Warranty





## TDA-595<sup>®</sup>

### Multifunction Treadmill with 18.5" Touch Screen



<b>Motor</b>	4.0HP DC GREEN Efficient Motor
<b>Max User Weight</b>	150KG
<b>Incline</b>	15 Level Auto Incline
<b>Running Surface</b>	1480 X 520mm / 58.2 X 20.4inches
<b>Running Belt</b>	Diamond strip Anti- static running belt
<b>Rollers</b>	Precision-machined, steel crowned rollers keep belt centered and running smoothly to reduce noise and wear
<b>Shock Absorption</b>	Comfort Tech™ - 6 point commercial grade damping system with Double Layer Running Board for better shock absorption to reduce stress on your joints
<b>Program</b>	12 Preset workout, 3 User defined & 3 Target based modes
<b>Speed</b>	0.8 - 18.8km/hr Speed select hot keys
<b>Display</b>	47cm Full HD TFT display - Time, Speed, Distance, Incline, Calories & Pulse Sensor
<b>Others Features</b>	Wheels for transportation, Auto Lubrication, Foldable & Easy to install, Wi-Fi, AUX, Speaker, USB, Multimedia for Music, Videos, internet & more
<b>BMI</b>	It helps to know whether your fat is healthy or not.
<b>Multifunction</b>	Massager, Dumbbell, Sit-ups, and Twister
<b>Warranty</b>	Lifetime Frame Warranty, 3 Year Motor Warranty and 1 Year Parts & Labor Warranty



## DOMESTIC TREADMILLS WITH AC MOTORS

**TAM-225**



**TAC-225**



### TAM-225®

AC Motorized Treadmill with MP3 & iPad Holder

<b>Motor</b>	2.0HP AC Motor
<b>Max User Weight</b>	120KG
<b>Incline</b>	3 Level Manual Incline
<b>Running Surface</b>	1250 X 430mm / 49.2 X 16.9 inches
<b>Running Belt</b>	3.2mm Diamond wave running belt
<b>Rollers</b>	Precision-machined, steel crowned rollers keep belt centered and running smoothly to reduce noise and wear
<b>Shock Absorption</b>	4/pcs Absorptions absorption-patent to reduce stress on your joints.
<b>Program</b>	12 Pre-set workout & 3 Target based modes
<b>Speed</b>	0.8 - 14.0km/hr with Pulse Sensors
<b>Display</b>	12.7cm LCD Blue Screen - Time, Speed, Distance, Heart rate and Calories
<b>Others Features</b>	iPad Holder, Bottle & Accessories Holder, AUX & USB input, Hi-Fi Speaker, Foldable, Semi-Auto Lubrication, Easy Installation and Wheel for transportation
<b>Warranty</b>	Lifetime Frame Warranty, 3 Year Motor Warranty and 1 Year Parts & Labor Warranty

### TAC-225®

AC Motorized Treadmill with MP3 & iPad Holder

<b>Motor</b>	2.0HP AC Motor
<b>Max User Weight</b>	120KG
<b>Incline</b>	15 Level Auto Incline
<b>Running Surface</b>	1250 X 430mm / 49.2 X 16.9 inches
<b>Running Belt</b>	3.2mm Diamond wave running belt
<b>Rollers</b>	Precision-machined, steel crowned rollers keep belt centered and running smoothly to reduce noise and wear
<b>Shock Absorption</b>	4/pcs Absorptions absorption-patent to reduce stress on your joints.
<b>Program</b>	12 Pre-set workout & 3 Target based modes
<b>Speed</b>	0.8 - 14.0km/hr with Pulse Sensors
<b>Display</b>	12.7cm LCD Blue Screen - Time, Speed, Distance, Heart rate and Calories
<b>Others Features</b>	iPad Holder, Bottle & Accessories Holder, AUX & USB input, Hi-Fi Speaker, Foldable, Semi-Auto Lubrication, Easy Installation and Wheel for transportation
<b>Warranty</b>	Lifetime Frame Warranty, 3 Year Motor Warranty and 1 Year Parts & Labor Warranty



## DOMESTIC TREADMILLS WITH AC MOTORS

**TAM-230**



**TAC-230**



### TAM-230®

#### AC Motorized Treadmill with MP3 & iPad Holder

<b>Motor</b>	2.0HP AC Motor
<b>Max User Weight</b>	110KG
<b>Incline</b>	6 Level Manual Incline
<b>Running Surface</b>	48.4 X 18.1 inch / 1230mm X460mm
<b>Running Belt</b>	Diamond wave running belt
<b>Rollers</b>	Precision-machined, steel crowned rollers keep belt centered and running smoothly to reduce noise and wear.
<b>Shock Absorption</b>	4/pcs Absorptions absorption-patent to reduce stress on your joints.
<b>Program</b>	12 Pre-set workout & 3 Target based modes
<b>Speed</b>	0.8 - 14.0km/hr with Pulse Sensors
<b>Display</b>	5inch LCD Display - Time, Speed, Distance, Heart rate, Calories, Fat Measure
<b>Others Features</b>	iPad Holder, Bottle & Accessories Holder, AUX & USB input, Speaker, Foldable, Stylish and safe design of comprehensively rapped edges, Easy Installation and Wheel for transportation
<b>Warranty</b>	Lifetime Frame Warranty, 3 Year Motor Warranty and 1 Year Parts & Labor Warranty

### TAC-230®

#### AC Motorized Treadmill with MP3 & iPad Holder

<b>Motor</b>	2.0HP AC Motor
<b>Max User Weight</b>	110KG
<b>Incline</b>	15 Levels Auto incline
<b>Running Surface</b>	1230X460mm / 48.4X18.1inch
<b>Running Belt</b>	Diamond wave running belt
<b>Rollers</b>	Precision-machined, steel crowned rollers keep belt centered and running smoothly to reduce noise and wear.
<b>Shock Absorption</b>	Double Layer Running Board for better shock absorption.
<b>Program</b>	12 Pre-set workout & 3 Target based modes
<b>Speed</b>	0.8 - 14.0km/hr with Pulse Sensors
<b>Display</b>	5inch LCD Display - Time, Speed, Distance, Heart rate, Calories, Fat Measure
<b>Others Features</b>	iPad Holder, Bottle & Accessories Holder, AUX & USB input, Speaker, Foldable, Stylish and safe design of comprehensively rapped edges, Easy Installation and Wheel for transportation
<b>Warranty</b>	Lifetime Frame Warranty, 3 Year Motor Warranty and 1 Year Parts & Labor Warranty

## TAC-330<sup>®</sup>

### Semi-Commercial Treadmill with Semi-Auto Lubricating



<b>Motor</b>	3.0HP AC Motor
<b>Max User Weight</b>	130KG
<b>Incline</b>	15 Level Auto Incline
<b>Running Surface</b>	1300 x 450mm / 51.1 x 17.7inches
<b>Running Belt</b>	3.2mm Diamond wave running belt
<b>Rollers</b>	Precision-machined, steel crowned rollers keep belt centered and running smoothly to reduce noise and wear
<b>Shock Absorption</b>	Dual spring shock absorption equipped with double layer running board to reduce stress on your joints.
<b>Program</b>	12 Pre-set workout & 3 target based modes
<b>Speed</b>	0.8 - 15.0km/hr
<b>Display</b>	12.7cm LCD Blue Screen -Time, Speed, Distance, Calories & Heart rate
<b>Others Features</b>	Semi-Auto Lubrication, USB & AUX input, Hydraulic Soft drop System (HSS) <sup>™</sup> Speaker, iPad Holder and Wheels for transportation
<b>Warranty</b>	Lifetime Frame Warranty, 3 Year Motor Warranty and 1 Year Parts & Labor Warranty



## TAC-360<sup>®</sup>

### AC Motorized Treadmill with Auto Lubrication

<b>Motor</b>	3.0HP AC Motor
<b>Max User Weight</b>	140KG
<b>Incline</b>	15 Level Auto Incline
<b>Running Surface</b>	1350 X 480mm / 53.1 X 18.8 inches
<b>Running Belt</b>	3.2 Diamond wave running belt
<b>Rollers</b>	Precision-machined, steel crowned rollers keep belt centered and running smoothly to reduce noise and wear
<b>Shock Absorption</b>	Dual spring shock absorption system with ComfortTech <sup>™</sup> - 6-point commercial grade damping system to reduce stress on your joints.
<b>Program</b>	12 Pre-set Programs & 3 Target-based modes
<b>Speed</b>	1.0-18km/hr with speed buttons on handrail
<b>Display</b>	17.7cm LCD Display - Time, Speed, Distance, Calories, Heart rate and Fat Measure
<b>Others Features</b>	iPad Holder, AUX & USB input, Hi-Fi Speaker, Foldable (HSS), Auto Lubrication, Easy Installation and Wheel for transportation
<b>Warranty</b>	Lifetime Frame Warranty, 3 Year Motor Warranty and 1 Year Parts & Labor Warranty

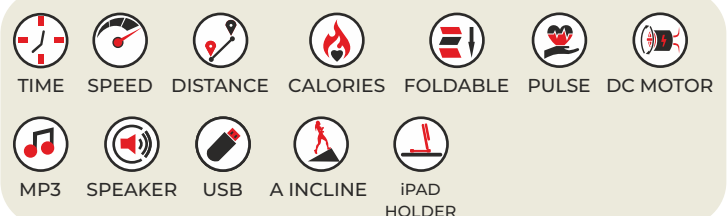



## TAC-400®

Semi-Commercial AC Treadmill with Android & iOS App



<b>Motor</b>	4.0HP AC Motor
<b>Max User Weight</b>	130KG
<b>Incline</b>	18 Level Auto Incline
<b>Running Surface</b>	1360 x 475mm / 53.5 x 18.7inches
<b>Running Belt</b>	3.2mm Diamond strip Anti-static running belt.
<b>Rollers</b>	Precision-machined, steel crowned rollers keep belt centered and running smoothly to reduce noise and wear
<b>Shock Absorption</b>	Octo Flexi rubber cushion with double layer running board for better shock absorption to reduce stress on your joints.
<b>Program</b>	12 Pre-set workout & 3 Target based modes
<b>Speed</b>	1.0 - 18.0km/hr
<b>Display</b>	17.9cm Blue LCD display with 400m track UI-Time, Speed, Distance, Calories, Pulse, Incline and BMI
<b>Others Features</b>	Wheel for transportation and Easy to Install, Foldable, Bluetooth for Android & iOS App, USB for charging & AUX input Cooling Fan, Speaker, iPad Holder
<b>Warranty</b>	Lifetime Frame Warranty, 3 Year Motor Warranty and 1 Year Parts & Labor Warranty



## TAC-510®

Semi-Commercial AC Treadmill with 7.1" LCD Display



<b>Motor</b>	4.5HP AC Commercial Motor
<b>Max User Weight</b>	150KG
<b>Incline</b>	15 Level Auto Incline
<b>Running Surface</b>	1400 X 520mm / 55.1 X 20.4 inches
<b>Running Belt</b>	3.2mm Diamond strip anti-static running belt.
<b>Rollers</b>	Precision-machined, steel crowned rollers keep belt centered and running smoothly to reduce noise and wear
<b>Shock Absorption</b>	ComfortTech 6-Point Commercial Grade Damping System with Double Layer Running Board
<b>Program</b>	12 Pre-set workout & 3 target based modes
<b>Speed</b>	0.8 - 20.0km/hr
<b>Display</b>	18cm Blue LCD Display-Pulse, Incline, Time, Speed, Distance, Calories & Body fat
<b>Others Features</b>	Semi-Auto Lubrication, AUX & USB input, Speaker, HSS System, Universal Wheel for transportation and Easy to Install
<b>Warranty</b>	Lifetime Frame Warranty, 3 Year Motor Warranty and 1 Year Parts & Labor Warranty





## TAC-515®

Semi-Commercial AC Treadmill with Android & iOS App

<b>Motor</b>	5.0HP AC Motor
<b>Max User Weight</b>	150KG
<b>Incline</b>	18 Level Auto Incline
<b>Running Surface</b>	1480 X 500mm / 58.2 X 19.6inches
<b>Running Belt</b>	3.2mm Diamond strip anti-static running belt.
<b>Rollers</b>	Precision-machined, steel crowned rollers keep belt centered and running smoothly to reduce noise and wear
<b>Shock Absorption</b>	Double Layer Running Board with shock spring for better shock absorption to reduce stress on your joints.
<b>Program</b>	24 Pre-set workout & 3 target based modes
<b>Speed</b>	0.8 - 18.0km/hr
<b>Display</b>	20.3cm LCD display-Time, Speed, Distance, Calories, Pulse, Incline & BMI
<b>Others Features</b>	Bluetooth app for Android & iOS, Mp3 & USB input Cooling Fan, iPad holder, HSS System, Wheel for transportation and Easy to Install
<b>Warranty</b>	Lifetime Frame Warranty, 3 Year Motor Warranty and 1 Year Parts & Labor Warranty



## TAC-550®

Semi-Commercial Motorized Treadmill with 10.1inch Touch Screen

<b>Motor</b>	5.0HP AC Motor
<b>Max User Weight</b>	150KG
<b>Incline</b>	15 Level Auto Incline
<b>Running Surface</b>	1450 X 580mm / 57 X 22.8inches
<b>Shock Absorption</b>	Super Shock Reducing Function and Oil Pressure Shock Reducing Springs
<b>Foldable</b>	Moveable & Foldable
<b>Program</b>	36 6 Preset Workout Programs
<b>Speed</b>	1.0 - 20km/hr
<b>Display</b>	10.1inch Touch Screen - Time, Speed, Distance, Calories, Pulse, Programs, Incline and Fat Measure
<b>Connectivity</b>	MP3 & USB input & High Quality Speakers, iPad Holder
<b>Warranty</b>	Lifetime Frame Warranty, 3 Years Motor Warranty, 1 Year Parts and Labour Warranty



*New Launch*





## TAC-585<sup>®</sup>

Semi-Commercial Motorized Treadmill with 15.6inch Touch Screen

Motor	5.0HP AC Motor
Max User Weight	150KG
Incline	15 Level Auto Incline
Running Surface	1450 X 580mm / 57 X 22.8inches
Display	15.6inch Touch Screen – Time, Speed, Distance, Calories, Pulse, Programs, Incline and Fat Measure
Shock Absorption	Super Shock Reducing Function and Oil Pressure Shock Reducing Springs
Foldable	Moveable & Foldable
Program	36 Preset Workout Programs
Connectivity	MP3 & USB input
Speaker	High Quality Speakers
Lubrication	Auto Lubrication
Warranty	Lifetime Frame Warranty, 3 Years Motor Warranty, 1 Year Parts and Labour Warranty



New Launch



## TAC-650<sup>®</sup>

Semi-Commercial Motorised AC Treadmill (7" TFT Screen)

Motor	5.0HP AC Motor
Max User Weight	150KG
Incline	18 Level Auto Incline
Running Surface	1500 X 580mm / 59 X 22.8inches
Running Belt	3.2mm Diamond strip anti-static running belt.
Rollers	Precision-machined, steel crowned rollers keep belt centered and running smoothly to reduce noise and wear
Run Board	18mm thickness composed of high density fibre board core with phenolic laminate bonded
Shock Absorption	Double Layer Running Board with 8 big shock spring for better shock absorption to reduce stress on your joints
Program	12 Preset workout with HRC Healing Function & 3 target based modes
Speed	0.8 - 20.8km/hr
Display	Bright Blue 17.9cm LCD window display - Time, Speed, Distance, Incline, Calories & Heart rate on crossbar handle
Others Features	Emergency stop button, Wheels for transportation, Foldable and Easy to install, iPad holder, AUX, USB input & Speaker
BMI	It helps to know whether your fat is healthy or not
Warranty	Lifetime Frame Warranty, 3 Year Motor Warranty and 1 Year Parts & Labor Warranty









## EH-200®

### Elliptical Cross Trainer with Hand Pulse

<b>Display</b>	LCD display - Time, Speed, Distance, Calories, Pulse & Scan
<b>Drive System</b>	Fan-wheel chain drive
<b>Resistance</b>	Micro adjustable tension control
<b>Max User Weight</b>	100KG
<b>Pedals</b>	Comfortable Anti-slip pedals
<b>Crank</b>	Two way crank system
<b>Others Features</b>	Wheels for transportation, Resistance control knob, Soft adjustable seat, Adjustable handle bar & Heart rate sensor on handle
<b>Warranty</b>	1 Year Limited Warranty

## EH-250S®

### Elliptical Cross Trainer with Adjustable Seat

<b>Display</b>	LCD Display - Time, Speed, Distance, Calories and Pulse
<b>Flywheel</b>	6KG flywheel
<b>Resistance</b>	8 Level Resistance Adjustable
<b>Max User Weight</b>	100KG
<b>Saddle</b>	Up/Down, Forward/Backward Adjustment
<b>Pedals</b>	Large Anti-slip Pedals
<b>Crank</b>	1pcs crank
<b>Others Features</b>	Heart Rate Sensor on Handle-Exercise /Body Building/Lose & Moving Handles.
<b>Warranty</b>	1 Year Manufacturer Warranty.



## EH-250S®

### Elliptical Cross Trainer with Adjustable Seat

<b>Display</b>	LCD Display - Time, Speed, Distance, Calories and Pulse
<b>Flywheel</b>	7KG flywheel
<b>Resistance</b>	8 Level Resistance Adjustable
<b>Max User Weight</b>	100KG
<b>Saddle</b>	Up/Down, Forward/Backward Adjustment
<b>Pedals</b>	Large Anti-slip Pedals
<b>Crank</b>	1pc Crank
<b>Others Features</b>	Heart rate sensor on handle-Exercise /Body Building/Lose & Moving Handles
<b>Warranty</b>	1 Year Limited Warranty





## EH-260S®

### Elliptical Cross Trainer with Hand Pulse

<b>Display</b>	LCD Display - Time, Speed, Distance, Calories, Pulse
<b>Flywheel</b>	5KG flywheel
<b>Resistance</b>	8 Level Resistance control by knob
<b>Max User Weight</b>	100KG
<b>Pedals</b>	Large Anti-slip Pedals
<b>Seat</b>	Adjustable seat (Vertically or Horizontally)
<b>Hand Pulse</b>	Heart rate sensor on handle
<b>Crank</b>	1pc Crank
<b>Others Features</b>	Moving handles with grip and easy to use.
<b>Warranty</b>	1 Year Manufacturer Warranty.

## EH-300®

### Elliptical Cross Trainer with Hand Pulse

<b>Display</b>	LCD Display - Time, Speed, Distance, Calories, Pulse and BMI
<b>Flywheel</b>	6KG Flywheel
<b>Resistance</b>	8 Level Resistance
<b>Max User Weight</b>	110KG
<b>Pedals</b>	Oversized pedals can safely secure feet of every size
<b>Crank</b>	One, Dia 152.4 Turnplate
<b>Hand Pulse</b>	Heart rate sensor on handle Paint Quality
<b>Others Features</b>	Tablet or Smart Phone holder
<b>Warranty</b>	1 Year Manufacturer Warranty.



## EH-350S®

### Magnetic Elliptical Cross Trainer with SOFT Seat

<b>Display</b>	LCD Display - Time, Speed, Distance, Calories, Pulse and BMI
<b>Flywheel</b>	6KG Flywheel
<b>Resistance</b>	8 Level Resistance
<b>Max User Weight</b>	120KG
<b>Pedals</b>	Oversized pedals can safely secure feet of every size
<b>Seat</b>	Seat can be Adjustable Horizontally & Vertically
<b>Certificate</b>	CE, ROSH, ISO9001
<b>Hand Pulse</b>	Heart rate sensor on handle
<b>Others Features</b>	Wheels for Transportation
<b>Warranty</b>	1 Year Limited Warranty.







**EH-750<sup>®</sup>**

**Elliptical Cross Trainer**

<b>Display</b>	LCD Display - Scan, Time, Speed, Distance, Calories, Pulse, RPM, Recovery
<b>Flywheel</b>	9KG Flywheel
<b>Stride Length</b>	330 x 175mm
<b>Resistance</b>	16 Level Electromagnetic Tension Control
<b>Max User Weight</b>	120KG
<b>Pedals</b>	Large Anti-slip Pedals
<b>Crank Arm</b>	Disc Type
<b>Hand Pulse</b>	Heart rate sensor on handle
<b>Certificate</b>	EN957, RoHS
<b>Others Features</b>	Adaptor-Water Bottle Cage and Two Wheels for transportation
<b>Warranty</b>	1 Year Manufacturer Warranty.

**EH-760<sup>®</sup>**

**Elliptical Cross Trainer with Water Bottle Cage**

<b>Display</b>	LCD Display - Time, Speed, Distance, Calories, Pulse, RPM, Recovery
<b>Flywheel</b>	12KG Flywheel
<b>Resistance</b>	32 Level Resistance
<b>Max User Weight</b>	150KG
<b>Brake System</b>	Motorized Magnetic Brake System
<b>Programs</b>	12 Preset Programs
<b>Pedals</b>	Large Anti-Slip Pedals
<b>Hand Pulse</b>	Heart Rate Sensor on Handle
<b>Stride Length</b>	14 inches
<b>Others Features</b>	Device holder for Smart Phone or iPad and Water Bottle Cage
<b>Warranty</b>	1 Year Manufacturer Warranty.



**EH-800<sup>®</sup>**

**Elliptical Cross Trainer**

<b>Flywheel</b>	9KG
<b>Max User Weight</b>	120KG
<b>Drive System</b>	Belt Drive System
<b>Resistance</b>	32 Levels Magnetic Resistance
<b>Stride Length</b>	15inches
<b>Display</b>	131*59 (mm) LCD Display - Time, Speed, Distance, Calorie, Pulse, Scan, Recovery, Body fat, RPM, Manual
<b>Crank</b>	Disc
<b>Pedals</b>	Anti-slip large pedals for comfortable workout
<b>Other</b>	iPad Holder, Pulse Sensors, wheels for transportation
<b>Warranty.</b>	1 Year Manufacturer Warranty.



## EH-850<sup>®</sup>

Elliptical Cross Trainer with Hand Pulse, Water Bottle



<b>Display</b>	LCD Display - Scan, Time, Speed, Distance, Calories, Pulse, RPM, Resistance level, Watts,
<b>Flywheel</b>	14KG Flywheel
<b>Resistance</b>	32 Level Resistance
<b>Max User Weight</b>	150KG
<b>Pedals</b>	Anti-slip Pedals with Adjustable Foot Strap
<b>Crank Arm</b>	Disc Type
<b>Stride Length</b>	435 x 217mm
<b>Hand Pulse</b>	Heart Rate Sensor on Handle
<b>Certificate</b>	EN957, RoHS
<b>Others Features</b>	Adaptor-Tablet or Smart Phone holder, Water Bottle Cage and Two Wheels for transportation
<b>Warranty</b>	1 Year Manufacturer Warranty.

## EC-900<sup>®</sup>

Elliptical Cross Trainer with Water Bottle Cage

<b>Display</b>	15inch Backlight Display - Time, Speed, Distance, Calories and Pulse
<b>Flywheel</b>	150KG
<b>Resistance</b>	8 Level Manual Resistance
<b>Max User Weight</b>	150KG
<b>Drive System</b>	Rear Drive Belt System
<b>Power Source</b>	2 x AA Batteries
<b>Shell</b>	Food Grade ABS
<b>Others Features</b>	iPad Holder and Wheels for Easy Transportation
<b>Warranty</b>	1 Year Manufacturer Warranty.



## EC-1000<sup>®</sup>

Semi-Commercial Elliptical Cross Trainer



<b>Flywheel</b>	12KG Flywheel
<b>Max User Weight</b>	130KG
<b>Drive System</b>	Belt Drive System
<b>Resistance</b>	32 Levels Magnetic Resistance
<b>Stride Length</b>	19inches
<b>Display</b>	131*59 (mm) LCD Display - Time, Speed, Distance, Calorie, Pulse, Scan, Recovery, Body fat, RPM, Manual
<b>Crank</b>	Disc
<b>Pedals</b>	Anti-slip large pedals for comfortable workout
<b>Other</b>	iPad Holder, Pulse Sensors, wheels for transportation
<b>Warranty.</b>	1 Year Manufacturer Warranty.



RECUMBENT BIKE  
RECUMBENT BIKE  
RECUMBENT BIKE

RECUMBENT BIKE

RECUMBENT BIKE  
RECUMBENT BIKE

# RECUMBENT BIKE

RECUMBENT BIKE RECUMBENT BIKE RECUMBENT BIKE RECUMBENT BIKE

RECUMBENT BIKE  
RECUMBENT BIKE  
RECUMBENT BIKE  
RECUMBENT BIKE

RECUMBENT BIKE  
RECUMBENT BIKE  
RECUMBENT BIKE

RECUMBENT BIKE  
RECUMBENT BIKE  
RECUMBENT BIKE  
RECUMBENT BIKE

RECUMBENT BIKE  
RECUMBENT BIKE  
RECUMBENT BIKE  
RECUMBENT BIKE

RECUMBENT BIKE RECUMBENT BIKE

RECUMBENT BIKE RECUMBENT BIKE

RECUMBENT BIKE RECUMBENT BIKE

RECUMBENT BIKE RECUMBENT BIKE

RECUMBENT BIKE

RECUMBENT BIKE

RECUMBENT BIKE  
RECUMBENT BIKE  
RECUMBENT BIKE

RECUMBENT BIKE

RECUMBENT BIKE

RECUMBENT BIKE  
RECUMBENT BIKE

RECUMBENT BIKE  
RECUMBENT BIKE

RECUMBENT BIKE

RECUMBENT BIKE

RECUMBENT BIKE

RECUMBENT BIKE

RECUMBENT BIKE

RECUMBENT BIKE

RECUMBENT BIKE  
RECUMBENT BIKE



## BR-600®

### Magnetic Recumbent Bike



<b>Display</b>	LCD display - Time, Speed, Distance, Odometer, Scan, Calories and Hand Pulse
<b>Flywheel</b>	4KG, Two Way
<b>Drive System</b>	Belt drive
<b>Resistance</b>	16 Level Tension
<b>Max User Weight</b>	110KG
<b>Pedals</b>	Comfortable Anti-Slip pedals
<b>Seat</b>	The comfort seat and back cushion provides exceptional comfort
<b>Crank</b>	6", 1pc Crank
<b>Others Features</b>	iPad holder, Wheels for transportation, Resistance controller, Hand pulse on the handle bar, Adjustable rear stabilizer in height
<b>Warranty</b>	1 Year Manufacturer Warranty.

## BR-700®

### Magnetic Recumbent Bike

<b>Display</b>	LCD display - Time, Speed, Distance, Odometer, Scan, Calories and Hand Pulse
<b>Flywheel</b>	7KG, One Way
<b>Drive System</b>	Belt drive
<b>Resistance</b>	8 Level Tension
<b>Max User Weight</b>	110KG
<b>Pedals</b>	Comfortable Anti-Slip pedals
<b>Seat</b>	The comfort seat with deluxe mesh back provides exceptional comfort
<b>Crank</b>	6", 3pcs Crank
<b>Others Features</b>	iPad holder, Wheels for transportation, Resistance controller, Hand pulse on the handle bar, Adjustable front and rear stabilizer in height
<b>Warranty</b>	1 Year Manufacturer Warranty.



## BR-800<sup>®</sup>

### Magnetic Recumbent Bike



<b>Display</b>	LCD display - Time, Speed, Distance, Odometer, Scan, Calories and Hand Pulse
<b>Flywheel</b>	6KG, Two Way
<b>Drive System</b>	Belt drive
<b>Resistance</b>	8 Level Tension
<b>Max User Weight</b>	120KG
<b>Pedals</b>	Double Color Bigger Pedal
<b>Seat</b>	The comfort seat and back cushion provides exceptional comfort
<b>Crank</b>	6.7", 3pc crank
<b>Others Features</b>	iPad holder, Wheels for transportation, Resistance controller, Hand pulse on the handle bar, HDR foam grip, Adjustable rear stabilizer in height
<b>Warranty</b>	1 Year Manufacturer Warranty.

## BR-900<sup>®</sup>

### Magnetic Recumbent Bike

<b>Display</b>	LCD display - Time, Speed, Distance, Odometer, Scan, Calories and Hand Pulse
<b>Flywheel</b>	9KG, One Way
<b>Drive System</b>	Belt drive
<b>Resistance</b>	8 Level Tension
<b>Max User Weight</b>	135KG
<b>Pedals</b>	Comfortable Anti-Slip pedals
<b>Seat</b>	The comfort seat with deluxe and multi-angle adjustment mesh back provides exceptional comfort
<b>Crank</b>	6.7", 3pc crank
<b>Others Features</b>	iPad holder, Handlebar and wheels for easy transportation, Resistance controller, Hand pulse on the handle bar, HDR foam grip, Adjustable front and rear stabilizer in height
<b>Warranty</b>	1 Year Manufacturer Warranty.







## B-S2<sup>®</sup>

### Home Use Group Bike/Spin Bike



<b>Flywheel weight</b>	14KG
<b>Flywheel Thickness</b>	23MM
<b>Max User Weight</b>	140KG
<b>Display</b>	LCD Display - Time, Speed, Distance, Calories and Pulse
<b>Resistance</b>	Friction Braking System
<b>Saddle</b>	Up/Down, Forward/Backward Adjustment
<b>Pedals</b>	Anti-slip Pedals with Adjustable Foot Strap
<b>Handrail</b>	Vertical Adjustment (Up/Down)
<b>Material</b>	Steel + Advanced Plastic
<b>Main Function</b>	Exercise /Body Building/Lose
<b>Paint Quality</b>	Anti-bacterial Powder Coat Finish
<b>Others Features</b>	Mobile Phone Holder, APP and Wheels for Easy Transportation
<b>Warranty</b>	1 Year Manufacturer Warranty

## BS-130<sup>®</sup>

### Home Use Group Bike/Spin Bike

<b>Flywheel weight</b>	8KG
<b>Max User Weight</b>	130KG
<b>Display</b>	LCD Display - Time, Speed, Distance, Calories and Pulse
<b>Resistance</b>	Friction Braking System
<b>Saddle</b>	Up/Down, Forward/Backward Adjustment
<b>Pedals</b>	Anti-slip Pedals with Adjustable Foot Strap
<b>Handrail</b>	Vertical Adjustment (Up/Down)
<b>Material</b>	Steel + Advanced Plastic
<b>Main Function</b>	Exercise / Body Building
<b>Paint Quality</b>	Anti-bacterial Powder Coat Finish
<b>Others Features</b>	Water Bottle Holder and Wheels for Easy Transportation
<b>Warranty</b>	1 Year Manufacturer Warranty



## BS-140®

### Home Use Group Bike/Spin Bike



<b>Flywheel weight</b>	13KG, Two way rotation
<b>Drive System</b>	Belt Drive
<b>Max User Weight</b>	140KG
<b>Display</b>	LCD Display - Time, Speed, Distance, Calories, Pulse
<b>Resistance</b>	+/- limitless resistance with wool felt fleece brake system
<b>Saddle</b>	Up/Down, Forward/Backward Adjustment
<b>Pedals</b>	Anti-slip Pedals with Adjustable Foot Strap
<b>Crank</b>	1pc Crank
<b>Brake System</b>	By pressing the knob
<b>Gross Weight</b>	33KG
<b>Dimension</b>	103 x 45 x 105cm
<b>Paint Quality</b>	Anti-bacterial Powder Coat Finish
<b>Others Features</b>	Double direction with direct push emergency stop
<b>Warranty</b>	1 Year Manufacturer Warranty

## BS-150®

### Home Use Group Bike with iPad & Bottle holder

<b>Flywheel weight</b>	8KG
<b>Drive System</b>	Belt Drive
<b>Max User Weight</b>	110KG
<b>Display</b>	LCD Display – Time, Speed, Distance, Scan, Calorie and Pulse
<b>Resistance</b>	Micro-tension Control Adjustable Mechanical esistance
<b>Heart Rate</b>	Heart rate sensors on handle
<b>Handle</b>	Handle can be adjusted vertically
<b>Seat</b>	Seat can be adjusted horizontally and vertically.
<b>Pedals</b>	Anti-slip Pedals with Adjustable Foot Strap
<b>Crank</b>	3pc Crank
<b>Brake System</b>	By pressing the knob
<b>Gross Weight</b>	30KG
<b>Dimension</b>	113 x 48 x 115cm
<b>Others Features</b>	Bottle & iPad holder, Wheels for easy transportation
<b>Warranty</b>	1 Year Manufacturer Warranty



## BS-151<sup>®</sup>

Home Use Group Bike/Spin Bike

<b>Flywheel weight</b>	10KG
<b>Flywheel Thickness</b>	23MM
<b>Max User Weight</b>	140KG
<b>Display</b>	LCD Display - Time, Speed, Distance, Calories and Pulse
<b>Resistance</b>	Friction Braking System
<b>Saddle</b>	Up/Down, Forward/Backward Adjustment
<b>Pedals</b>	Anti-slip Pedals with Adjustable Foot Strap
<b>Handrail</b>	Vertical Adjustment (Up/Down)
<b>Material</b>	Steel + Advanced Plastic
<b>Main Function</b>	Exercise /Body Building/Lose
<b>Paint Quality</b>	Anti-bacterial Powder Coat Finish
<b>Others Features</b>	Mobile Phone Holder, APP and Wheels for Easy Transportation
<b>Warranty</b>	1 Year Manufacturer Warranty



## BS-155<sup>®</sup>

Home Use Group Bike/Spin Bike

<b>Flywheel weight</b>	15KG, Two way rotation
<b>Drive System</b>	Belt Drive
<b>Max User Weight</b>	150KG
<b>Display</b>	LCD Display - Time, Speed, Distance, Calories, Pulse
<b>Resistance</b>	+/- Levels of resistance
<b>Seat</b>	Seat can be adjusted vertically & horizontally
<b>Pedals</b>	Anti-slip Pedals with Adjustable Foot Strap
<b>Crank</b>	3pc Crank
<b>Brake System</b>	By pressing the knob
<b>Gross Weight</b>	41KG
<b>Dimension</b>	118 x 48 x 105cm
<b>Paint Quality</b>	Anti-bacterial Powder Coat Finish
<b>Others Features</b>	Double direction with direct push emergency stop
<b>Warranty</b>	1 Year Manufacturer Warranty





## BS-160<sup>®</sup>

### Home Use Group Bike/Spin Bike

<b>Flywheel weight</b>	18KG, Two way Rotation Post Positive Flywheel
<b>Drive System</b>	Belt Drive
<b>Max User Weight</b>	150KG
<b>Display</b>	LCD Display - Time, Speed, Distance, Calories, Pulse
<b>Resistance</b>	1 - 8 Level Resistance Micro-adjustable System
<b>Seat</b>	Seat can be adjusted vertically & horizontally
<b>Pedals</b>	Anti-slip Pedals with Adjustable Foot Strap
<b>Crank</b>	3pc Crank
<b>Brake System</b>	By pressing the knob
<b>Gross Weight</b>	45KG
<b>Dimension</b>	137 x 50 x 116cm
<b>Paint Quality</b>	Anti-bacterial Powder Coat Finish
<b>Others Features</b>	Double direction with direct push emergency stop
<b>Warranty</b>	1 Year Manufacturer Warranty



## BS-2070C<sup>®</sup>

### Home Use Group Bike/Spin Bike

<b>Flywheel weight</b>	20KG, Two way Rotation Post Positive Flywheel
<b>Drive System</b>	Belt Drive
<b>Max User Weight</b>	170KG
<b>Display</b>	LCD Display - Time, Speed, Distance, Calories, Pulse
<b>Resistance</b>	Variable linear increase
<b>Seat</b>	Seat can be adjusted vertically & horizontally
<b>Pedals</b>	SPD Racing Pedals with Adjustable Foot Strap
<b>Crank</b>	3pc Crank
<b>Brake System</b>	By pressing the knob
<b>Gross Weight</b>	51KG
<b>Paint Quality</b>	Anti-bacterial Powder Coat Finish
<b>Others Features</b>	Handle can be adjusted horizontally and vertically, Transport wheels for easy movement
<b>Warranty</b>	1 Year Manufacturer Warranty





## BU-200<sup>®</sup>

### Magnetic Upright Bike for Home Use



<b>Drive System</b>	Belt Drive
<b>Max User Weight</b>	100KG
<b>Display</b>	LCD display - Scan, Time, Speed, Distance, Odometer, Calories and Pulse
<b>Resistance</b>	Micro adjustment tension control
<b>Seat</b>	Comfortable cushion seat and vertical adjustment
<b>Pedals</b>	Anti-skid pedals with adjustable foot straps
<b>Crank</b>	5.5inches, 1pc Crank
<b>Paint Quality</b>	Anti-bacterial Powder Coat Finish
<b>Others Features</b>	Heart rate sensors on handle grip & HDR foam grip
<b>Warranty</b>	1 Year Manufacturer Warranty

## BU-200<sup>®</sup>

### Magnetic Upright Bike for Home Use

<b>Drive System</b>	Belt Drive
<b>Max User Weight</b>	100KG
<b>Display</b>	LCD display - Scan, Time, Speed, Distance, Odometer, Calories and Pulse
<b>Resistance</b>	Micro adjustment tension control
<b>Seat</b>	Comfortable cushion seat and vertical adjustment
<b>Pedals</b>	Anti-skid pedals with adjustable foot straps
<b>Crank</b>	5.5inches, 1pc Crank
<b>Paint Quality</b>	Anti-bacterial Powder Coat Finish
<b>Others Features</b>	Heart rate sensors on handle grip & HDR foam grip
<b>Warranty</b>	1 Year Manufacturer Warranty
<b>Part No.</b>	AL156





## BU-200<sup>®</sup>

### Magnetic Upright Bike for Home Use



<b>Drive System</b>	Belt Drive
<b>Max User Weight</b>	100KG
<b>Display</b>	LCD display - Scan, Time, Speed, Distance, Odometer, Calories and Pulse
<b>Resistance</b>	Micro adjustment tension control
<b>Seat</b>	Comfortable cushion seat and vertical adjustment
<b>Pedals</b>	Anti-skid pedals with adjustable foot straps
<b>Crank</b>	5.5inches, 1pc Crank
<b>Paint Quality</b>	Anti-bacterial Powder Coat Finish
<b>Others Features</b>	Heart rate sensors on handle grip & HDR foam grip
<b>Warranty</b>	1 Year Manufacturer Warranty
<b>Part No.</b>	AL143

## BU-201<sup>®</sup>

### Dual Action Air Bike/Exercise Bike

<b>Drive System</b>	Belt Drive System
<b>Resistance</b>	Micro Adjustment Tension Control
<b>Max User Weight</b>	120KG
<b>Display</b>	LCD Display – Time, Speed, Distance, Calories and Scan
<b>Seat</b>	Ergonomic Adjustable Back Support System
<b>Pedals</b>	Anti-skid pedals with adjustable foot straps
<b>Handle</b>	Moving Handle Bar with Foam Hand Grips
<b>Crank</b>	Single Piece Crank
<b>Other Features</b>	High-Quality Steel Frame and Adjustable Seat Height
<b>Warranty</b>	1 Year Manufacturer Warranty



## BU-300®

### Magnetic Upright Bike for Home Use



<b>Flywheel</b>	2KG Outer Magnetic Wheel
<b>Drive System</b>	Belt Drive
<b>Max User Weight</b>	100KG
<b>Display</b>	LCD Display - Time, Distance, Speed, Calories and Hand Pulse
<b>Resistance</b>	Stepless Resistance Adjustable System
<b>Seat</b>	Comfortable cushion seat and vertical adjustment
<b>Pedals</b>	Anti-skid pedals with adjustable foot straps
<b>Heart rate</b>	Hand pulse sensors on handlebars
<b>Crank</b>	1pc Crank
<b>Paint Quality</b>	Anti-bacterial Powder Coat Finish
<b>Others Features</b>	Upright cycling that you can use in the comfort of your own home. Sturdy steel frame gives extra stability. Lightweight design & easy move and carry. Improve cardio, burn fat and gain strength.
<b>Warranty</b>	1 Year Manufacturer Warranty

## BU-350®

### Magnetic Upright Bike with iPad holder

<b>Flywheel</b>	2KG Outer Magnetic Wheel
<b>Drive System</b>	Belt transmission
<b>Resistance</b>	8-Level Resistance Adjustable
<b>Max User Weight</b>	100KG
<b>Brake System</b>	Magnetic
<b>Display</b>	LCD Display - Time, Distance, Speed, Odometer, Calories and Hand Pulse
<b>Seat</b>	Comfortable seat cushion, vertical adjustment
<b>Pedals</b>	Anti-slip pedals with adjustable foot-straps
<b>Handles</b>	Comfortable neoprene-covered handlebars
<b>Crank</b>	1pcs
<b>Heart rate</b>	Hand pulse sensors on handlebars
<b>Other Features</b>	Sturdy steel frame gives extra stability. Lightweight design & easy move and carry. Improve cardio, burn fat and gain strength. Great for relaxation after whole day work.
<b>Paint Quality</b>	Anti-bacterial powder Coat finish
<b>Warranty</b>	1 Year Manufacturer Warranty





## BU-400<sup>®</sup>

### Magnetic Upright Bike with iPad holder

<b>Flywheel</b>	3.5KG
<b>Drive System</b>	Belt transmission
<b>Resistance</b>	8-Level Resistance Adjustable
<b>Max User Weight</b>	110KG
<b>Brake System</b>	Magnetic
<b>Display</b>	LCD Display - Time, Distance, Speed, Odometer, Calories and Hand Pulse
<b>Seat</b>	Comfortable seat cushion, vertical adjustment
<b>Pedals</b>	Anti-slip pedals with adjustable foot-straps
<b>Handles</b>	Comfortable neoprene-covered handlebars
<b>Crank</b>	1pcs
<b>Heart rate</b>	Hand pulse sensors on handlebars
<b>Other Features</b>	Upright cycling that you can use in the comfort of your own home. Sturdy steel frame gives extra stability. Lightweight design & easy move and carry. Improve cardio, burn fat and gain strength. Great for relaxation after whole day work.
<b>Paint Quality</b>	Anti-bacterial powder Coat finish
<b>Warranty</b>	1 Year Manufacturer Warranty

## BU-510<sup>®</sup>

### Magnetic Upright Bike with LCD Display

<b>Flywheel</b>	4KG
<b>Drive System</b>	Belt transmission
<b>Resistance</b>	8-Level Resistance Adjustable
<b>Max User Weight</b>	100KG
<b>Brake System</b>	Silent, Frictionless Magnetic System
<b>Display</b>	LCD Display - Time, Distance, Speed, Calories, Scan and Hand Pulse
<b>Seat</b>	Comfortable seat cushion, vertical adjustment
<b>Pedals</b>	Anti-slip pedals with adjustable foot-straps
<b>Handles</b>	Comfortable neoprene-covered handlebars
<b>Crank</b>	1pcs
<b>Heart rate</b>	Hand pulse sensors on handlebars
<b>Other Features</b>	Sturdy steel frame gives extra stability. Lightweight design & easy move and carry. Improve cardio, burn fat and gain strength. Great for relaxation after whole day work.
<b>Paint Quality</b>	Anti-bacterial powder Coat finish
<b>Warranty</b>	1 Year Manufacturer Warranty





## BU-515<sup>®</sup>

### Magnetic Upright Bike with LCD Display



<b>Flywheel</b>	5KG
<b>Drive System</b>	Belt transmission
<b>Resistance</b>	8-Level Resistance Adjustable
<b>Max User Weight</b>	100KG
<b>Brake System</b>	Silent, Frictionless Magnetic System
<b>Display</b>	LCD Display - Time, Distance, Speed, Calories, Scan and Hand Pulse
<b>Seat</b>	Comfortable seat cushion, vertical adjustment
<b>Pedals</b>	Anti-slip pedals with adjustable foot-straps
<b>Handles</b>	Comfortable neoprene-covered handlebars
<b>Crank</b>	1pcs
<b>Heart rate</b>	Hand pulse sensors on handlebars
<b>Other Features</b>	Sturdy steel frame gives extra stability. Lightweight design & easy move and carry. Improve cardio, burn fat and gain strength. Great for relaxation after whole day work.
<b>Paint Quality</b>	Anti-bacterial powder Coat finish
<b>Warranty</b>	1 Year Manufacturer Warranty

## BU-610<sup>®</sup>

### Magnetic Upright Bike with LCD Display

<b>Flywheel</b>	6KG
<b>Drive System</b>	Belt transmission
<b>Resistance</b>	8-Level Resistance Adjustable
<b>Max User Weight</b>	100KG
<b>Brake System</b>	Silent, Frictionless Magnetic System
<b>Display</b>	LCD Display - Time, Distance, Speed, Calories, Scan and Hand Pulse
<b>Seat</b>	Comfortable seat cushion, vertical adjustment
<b>Pedals</b>	Anti-slip pedals with adjustable foot-straps
<b>Handles</b>	Comfortable neoprene-covered handlebars
<b>Crank</b>	1pcs
<b>Heart rate</b>	Hand pulse sensors on handlebars
<b>Other Features</b>	Sturdy steel frame gives extra stability. Lightweight design & easy move and carry. Improve cardio, burn fat and gain strength. Great for relaxation after whole day work.
<b>Paint Quality</b>	Anti-bacterial powder Coat finish
<b>Warranty</b>	1 Year Manufacturer Warranty



## BU-650<sup>®</sup>

### Magnetic Upright Bike with LCD Display



<b>Flywheel</b>	6KG
<b>Drive System</b>	Belt transmission
<b>Resistance</b>	8-Level Resistance Adjustable
<b>Max User Weight</b>	120KG
<b>Brake System</b>	Silent, Frictionless Magnetic System
<b>Display</b>	LCD Display - Time, Distance, Speed, Calories, Scan and Hand Pulse
<b>Seat</b>	Comfortable seat cushion, vertical adjustment
<b>Pedals</b>	Anti-slip pedals with adjustable foot-straps
<b>Handles</b>	Comfortable neoprene-covered handlebars
<b>Crank</b>	1pcs
<b>Heart rate</b>	Hand pulse sensors on handlebars
<b>Other Features</b>	Sturdy steel frame gives extra stability. Lightweight design & easy move and carry. Improve cardio, burn fat and gain strength. Great for relaxation after whole day work. Wheels for easy transportation
<b>Paint Quality</b>	Anti-bacterial powder Coat finish
<b>Warranty</b>	1 Year Manufacturer Warranty

## BU-740<sup>®</sup>

### Upright Exercise Bike with Hand Pulse, iPad Holder

<b>Flywheel</b>	8KG Flywheel
<b>Resistance</b>	10 Level Resistance
<b>Max User Weight</b>	120KG
<b>Display</b>	LCD Display - Scan, Time, Speed, Distance, Calories, Pulse, RPM, Recovery
<b>Pedals</b>	Anti-slip Pedals with Adjustable Foot Strap
<b>Handles</b>	Fixed Handle Bar with HDR Foam Grip
<b>Crank Arm</b>	3pcs
<b>Hand Pulse</b>	Heart rate sensor on handle
<b>Other Features</b>	Tablet or Smart Phone holder, Water Bottle Cage and Two Wheels for Transportation
<b>Warranty</b>	1 Year Manufacturer Warranty.



## BU-750<sup>®</sup>

### Upright Exercise Bike with Hand Pulse



<b>Flywheel</b>	9KG Flywheel
<b>Resistance</b>	32 Level Resistance
<b>Max User Weight</b>	120KG
<b>Display</b>	LCD Display - Scan, Time, Speed, Distance, Calories, Pulse, RPM, Recovery
<b>Pedals</b>	Anti-slip Pedals with Adjustable Foot Strap
<b>Handles</b>	Fixed Handle Bar with HDR Foam Grip
<b>Crank</b>	3pcs
<b>Hand Pulse</b>	Heart rate sensor on handle
<b>Other Features</b>	Water Bottle Cage and Two Wheels for transportation
<b>Warranty</b>	1 Year Manufacturer Warranty.

## BX-110SX<sup>®</sup>

### Magnetic Bike with Back Rest

<b>Flywheel</b>	4KG
<b>Drive System</b>	Ribbed Belt one-way
<b>Resistance</b>	8 Level by Manual
<b>Max User Weight</b>	110KG
<b>Brake System</b>	Magnetic
<b>Display</b>	LCD Display - Time, Distance, Speed, Odometer, Scan, Calories and Hand Pulse
<b>Seat</b>	The deluxe comfort seat provides exceptional comfort, Horizontal and Vertical adjustment
<b>Pedals</b>	Anti-slip Pedals with Adjustable Foot Strap
<b>Certification</b>	TUV / GS Approved
<b>En Standard</b>	ISO20957, EN957-9/class HC
<b>Heart rate</b>	Hand Pulse sensors on handlebars
<b>Transport Roller</b>	Wheels for easy movement
<b>Other Features</b>	Adjusting caps for uneven floor, Adjustable seat height for different users (7300820mm)
<b>Paint Quality</b>	Anti-bacterial powder Coat finish
<b>Warranty</b>	1 Year Manufacturer Warranty







## GH-130®

### Multi Function Home Gym

<b>Description</b>	Multi Function Home Gym
<b>Weight Stack</b>	61KG / 135LBS
<b>Max User Weight</b>	150KG / 330.6LBS
<b>Exercise</b>	Seated Bench Press, Abdominal Crunch, Triceps, Push Down, Lat Pull Down, Preacher Curl, Leg Extension
<b>Accessories</b>	Lat Pull Bar, Silver Bar & Ankle Strap
<b>Dimension</b>	103 x 131 x 240cm
<b>Paint Quality</b>	Anti-bacterial powder Coat finish
<b>Warranty</b>	1 Year Manufacturer Warranty



## GH-285®

### Multi Function Home Gym

<b>Description</b>	Multi-function Home Gym contoured, Deep padded seat, Back rest and Arm curl Pad
<b>Weight Stack</b>	68KG / 150LBS
<b>Max User Weight</b>	160KG / 352.7LBS
<b>Exercise</b>	Pec Dec Fly, Lat Pull Down, Preacher Curl, Seated Row, Leg Extension / Curl, Inner & Outer Thigh, Bench Press
<b>Accessories</b>	Lat Bar, Silver Bar, Single Strap, Ankle Strap & Triceps Rope
<b>Dimension</b>	175 x 86 x 198.5cm
<b>Paint Quality</b>	Anti-bacterial powder Coat finish
<b>Warranty</b>	1 Year Manufacturer Warranty



## GH-450<sup>®</sup>

### 3 Station Multi Function Home Gym



<b>Description</b>	3 Station home gym 148 lbs vinyl weight stack (14pcs X 10 lbs + 1 Pcs X 8 lbs) = Durable powder coated finish Dual-function leg developer with pivot point that properly aligns with the knee joints Aircraft-rated cables at 2000 lbs tensile strength
<b>Frame Construction</b>	50 x 1.5 m high and low pulleys for upper and lower body exercises adjustable preacher curl biceps pad for isolated biceps exercises 148 lbs. Selectrized weight stack Oversized foam roller pads offer comfort while performing leg exercises suspended weights behind a protective weight stack provide a safe workout
<b>Max User Weight</b>	160KG / 352.7LBS
<b>Exercise</b>	Lat Pull Bar, Silver Bar, Single Strap & Ankle Strap Dual-Function Leg Developer
<b>Dimension</b>	215 x 191 x 202cm
<b>Paint Quality</b>	Anti-bacterial powder Coat finish
<b>Warranty</b>	2 Year limited Manufacturer Warranty on Parts

## GH-450P<sup>®</sup>

### 3 Station Multi Function Home Gym with Punching Bag

<b>Description</b>	3 Station home gym 148 lbs vinyl weight stack (14pcs X 10 lbs + 1 Pcs X 8 lbs) = Durable powder coated finish Dual-function leg developer with pivot point that properly aligns with the knee joints Aircraft-rated cables at 2000 lbs tensile strength
<b>Frame Construction</b>	50 x 1.5 m high and low pulleys for upper and lower body exercises adjustable preacher curl biceps pad for isolated biceps exercises 148 lbs. Selectrized weight stack Oversized foam roller pads offer comfort while performing leg exercises suspended weights behind a protective weight stack provide a safe workout
<b>Max User Weight</b>	160KG / 352.7LBS
<b>Exercise</b>	Lat Pull Bar, Silver Bar, Single Strap & Ankle Strap Dual-Function Leg Developer
<b>Dimension</b>	215 x 191 x 202cm
<b>Paint Quality</b>	Anti-bacterial powder Coat finish
<b>Warranty</b>	2 Year limited Manufacturer Warranty on Parts

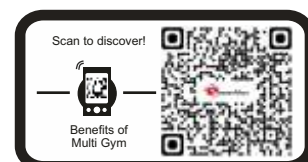



**BM-100A®**
**Multi-functional Bench Press**

<b>Function</b>	Multi-functional dumbbell bench
<b>Seat</b>	Seat & Backrest with comfortable cushion design
<b>Back Rest Incline</b>	5 Level Back Rest Incline Adjustment
<b>Back Rest Height Sizes</b>	Size1: 159.5 x 69 x 38cm Size2: 159.5 x 69 x 66.5cm Size3: 159.5 x 69 x 78cm Size4: 159.5 x 69 x 87cm
<b>Handlebar Height</b>	8 Level Handlebar Height Adjustment
<b>Max User Weight</b>	130kg
<b>Rear Foot Adjustment</b>	3 Level for Different Length
<b>N.W.</b>	21KG
<b>N.W.</b>	25KG
<b>Foldable Size</b>	156 x 69 x 24cm
<b>Assembly Size</b>	156 x 69 x 94.5cm
<b>Warranty</b>	1-Year Manufacturer Warranty on Frame.



## FOLDABLE ROWING MACHINE FOR HOME USE



### RH-150

Foldable Rowing Machine for Home use

- **Resistance System:** Water Resistance
- **Resistance Level:** 8 Level
- **Max. User Weight:** 135KG
- **Resistance System:** Magnetic Control Regulation
- **Display:** LCD Monitor – Time, Count, Total Count, Calorie, RPM
- **Slide Rail Material:** Aluminum alloy sliding rail
- **Slide Rail Length:** 760mm
- **Transmission System:** Pull rope using pulley
- **Power Source :** Battery (2\*AA)
- **Other Features:** Anti-slip Pedals with Adjustable Foot Strap, Soft Padded Sliding Seat, Foldable Rowing Machine
- **Warranty:** 1 Year Manufacturer Warranty



LCD Monitor



Transportation Wheels



## Rowing Machine with Digital Display for Home use



**RH-200**

**RH-250**

**RH-200**

**RH-250**

Rowing Machine with Digital Display for Home use

Rowing Machine with Digital Display for Home use

- **Flywheel Weight:** 4KG
- **Resistance Level:** 8 Level
- **Max. User Weight:** 110KG
- **Resistance System:** Magnetic Tension Control System
- **Display:** LCD Monitor – Stroke Count, Time, Calories, Distance
- **Slide Rail Material:** Aluminum
- **Slide Rail Length:** 94.5cm
- **Transmission System:** Pull rope using pulley
- **Power Source:** Battery (2\*AA)
- **Warranty:** 1 Year Parts, Components and Labor, Lifetime Frame Warranty

- **Flywheel Weight:** 4KG
- **Resistance Level:** 8 Level
- **Max. User Weight:** 120KG
- **Resistance System:** Magnetic Tension Control System
- **Display:** LCD Monitor – Scan, Stroke Count, Time, Calories, Speed, Reset
- **Slide Rail Material:** Aluminum
- **Slide Rail Length:** 105cm
- **Transmission System:** Pull rope using pulley
- **Power Source:** Battery (2\*AA)
- **Warranty:** 1 Year Parts, Components and Labor, Lifetime Frame Warranty



## Water Rowing Machine with Digital Display for Commercial use



### RWC-1000

Water Rowing Machine with Digital Display for Commercial use

- **Resistance System:** Water Resistance
- **Resistance Level:** 8 Level
- **Max. User Weight:** 135KG
- **Resistance System:** Water Resistance
- **Display:** LCD Monitor – Time, Time/500M, SPM, Distance, Strokes, Total Strokes, Calories Burned, and Pulse
- **Slide Rail Material:** Aluminum alloy sliding rail
- **Slide Rail Length:** 124.4cm
- **Sliding Distance:** 110cm
- **Transmission System:** Pull rope using pulley
- **Power Source :** Battery (2\*AA)
- **Other Features:** Comfortable Saddle, Large Foot Pedals, Anti-slip handle bars, Foldable, Wheels for transportation
- **Warranty:** 1 Year Parts, Components and Labor, Lifetime Frame Warranty



LCD Monitor



Transportation Wheels





## PMC-2600®

### Full Body Massage Chair

**Model Name:** im-OnCloudNine-2

53pcs Airbags with Zero Gravity and 3cm Wall Space

**Massage Modes:** Kneading, Tapping, Shiatsu, Knocking, Knead & Tap

**Purpose of Use:** Massage Chair - relaxing muscles, Moving, Improving blood flow temporarily alleviate joint pain, enhance detoxification

**Other Massage:** Air Pressure Massage for Shoulder, Arms and Calf, Rolling and Air Squeezing Massage for Feet

**Special Features:** Intelligent Auto Body Detection, UltraThin Massage, Space Saving Zero-Gravity, One Box Packaging

Bluetooth Music, Built-in Speakers, 17 Automatic Programs with Heat Therapy on Waist

93cm L-Rail, 110cm Massage Length and 22cm Foot Rest Extension

**Accessories:** Wired Colour LCD Remote, User Manual, Warranty Card

**Colour:** Royal Cream Body Cover with Golden Brown PU Leather Pad

**Power Source:** 220-240V

**Alternating Current:** 50/60Hz

**Power Consumption:** 150W

**Timer Given:** 8/10/20/30 minutes

**Maximum Operating Period:** 30 minutes

**Upright position:** 1130×750×1130mm

**Reclined position:** 1750×750×950mm

**N.W. / G.W.:** 83KG / 98KG



## PMC-3600®

### Full Body Massage Chair

**Model Name:** im-OnCloudNine-3

53pcs Airbags, 3D Massage Technology with Zero Gravity and 0cm Wall Space

**Massage Modes:** Kneading, Tapping, Pressing, Shiatsu, Knocking, Knead & Tap, Combinations

**Purpose of Use:** Massage Chair - relaxing muscles, Moving, Improving blood flow temporarily alleviate joint pain, enhance detoxification

**Other Massage:** Air Pressure Massage for Shoulder, Arms & Calf, Rolling and Air Squeezing Massage for Feet

**Special Features:** UltraThin 3D Massage Technology, Durable ABS Cover, Intelligent Auto Body Detection, Space Saving Zero-Gravity, Easy to Clean, Stylish and Elegant Design

Bluetooth Music, Built-in Speakers, USB for Mobile Charging, 16 Automatic Programs with Heat Therapy on Waist

93cm L-Rail, 110cm Massage Length and 23cm Foot Rest Extension

**Accessories:** Wired HD LCD Remote, User Manual in English, Leaflet, Warranty card

**Colour:** Snow White Body Cover with Rose Gold PU Leather Pad

**Power Source:** 220-240V

**Alternating Current:** 50/60Hz

**Power Consumption:** 200W

**Timer Given:** 8/10/20/30 minutes

**Maximum Operating Period:** 30 minutes

**Upright position:** 1475 x 820 x 1270mm

**Reclined position:** 1615 x 820 x 1180mm

**N.W. / G.W.:** 148KG / 178KG



## iS-7®

### Luxurious Massage Chair



**Technology:** Zero-space design

**Programs:** 4 Auto programs for choosing

Detect shoulder position automatically

4 rollers mechanism and C massage rail on the back, integrating kneading, tapping, precessing and shiatsu.

3 levels of intensity are adjustable and 3 back massage range are adjustable adjustable

Airbags for thigh and buttock, 3 levels of intensities are adjustable

Kneading for calve , and it can be turned to roller massage foot

APP and wireless controller for operating massage chair

**Power:** 135W

**Voltage:** AC 110~240V, 50-60HZ

**N.W.:** 43KG

**G.W.:** 53KG

**Operating Time:** 15 min

**Product Size:** 117 x 59 x 113cm

**Colour:** Orange

## iS-7R®

### Luxurious Rocking Massage Chair

**Technology:** Zero-space design

**Programs:** 4 Auto programs for choosing

Detect shoulder position automatically

4 rollers mechanism and C massage rail on the back, integrating kneading, tapping, precessing and shiatsu.

3 levels of intensity are adjustable and 3 back massage range are adjustable adjustable

Airbags for thigh and buttock, 3 levels of intensities are adjustable

Kneading for calve , and it can be turned to roller massage foot

APP and wireless controller for operating massage chair

**Power:** 135W

**Voltage:** AC 110~240V, 50-60HZ

**N.W.:** 43KG

**G.W.:** 53KG

**Operating Time:** 15 min

**Product Size:** 117 x 59 x 113cm

**Colour:** Brown



## PMC-2000<sup>®</sup>

### Elegant Massage Chair



**Technology:** 2D Intelligent Technology

**Programs:** 4-Auto Programs : Refresh, Relief, Relax, Recreation

**Massage Modes:** Manual Modes: Full and Partial Adjustment, Kneading, Knocking, Kneading + Knocking, Pressing, Tapping, Heating, Thai Stretch, Roller, Speed Adjustments, Massage Width & Point Adjustment Air Bag Strength Adjustment, Backrest & Leg rest Adjustment

**Purpose of Use:** Massage Chair - relaxing muscles, Moving, Improving blood flow temporarily alleviate joint pain, enhance detoxification

**Special Features:** U-Pillow Air Massage, Intelligent body scan technology, 3D massage technology with Heating Function, **Rail:** S Shape Rail Design

**Music/Connector:** With Blue tooth music to play music remotely from your device, **Accessories:** Ergonomic LCD Remote, User Manual in English, **Massage Length:** 79cm, **Foot Rest Extension:** 21cm

**Zero Gravity:** Zero Gravity luxury massage chair, **Air Bags:** 24, **Wall Space:** 10cm, **Power Source:** 220-240V, **Alternating Current :** 50/60Hz, **Power Consumption:** 150W

**Timer Given:** 15/10/15/20/25/30 minutes, **Maximum Operating Period :** 30 minutes

**Maximum Operating Period Position:** 120cm x 81cm x 126cm, **Reclined position:** 171 x 81 x 91cm, **Net weight:** 82KG, **Gross weight:** 102KG, **Rollers:** Eight Rollers, **Shape:** S shape, **Warranty:** 1 Year

## PMC-2100<sup>®</sup>

### Refreshing Massage Chair

**Programs:** 3 Auto Programs (Relax, Refresh and Stretch Mode)

**Massage Modes:** Kneading, Tapping, Shiatsu, Knocking, Pressing, Knead & Knock Combination, Rolling, Stretch, Finger Knead, Back Rubbing, 3 Auto Programs (Relax Mode, Refresh Mode, Stretch Mode)

**Purpose of Use :** Massage Chair - relaxing muscles, Moving, Improving blood flow temporarily alleviate joint pain, enhance detoxification

**Special Features:** Full Body Air Pressure massage at 3 Degrees Variable Intensity, Extendable Footrest, Heating with Smart, Thermostat for overheating protection, Foot Rollers, Intelligent 3D Massage Roller, Intelligent body scan technology, Acupoint and pulse Tracking, Patented micro-spatial intelligence slide forward

**Zero Gravity:** Zero Gravity massage chair, **Air Bags:** 32, **Airbag Intensity:** 3 Degrees, **Power Source:** 220-240V, **Alternating Current:** 50/60Hz, **Power Consumption:** 120W, **Wall Space:** 5cm

**Maximum Operating Period:** 30 minutes

**Available Colour:** Black

**Rail:** L-Rail Design, **Music/Connect/Control:** LCD Remote, **Max User Weight:** 120KG, **Accessories:** LCD Remote, User Manual in English, **Massage Length:** 136cm, Super Long Massage Track

**Noise level:** ( ≤ )60(dB) within 30cm, **Upright Position:** 143 x 76 x 112cm, **Recline Position:** 180 x 76 x 81.5cm, **Net weight:** 72KG, **Gross Weight:** 85KG, **Warranty:** 1 Year





## PMC-2101L<sup>®</sup>

### Refreshing Massage Chair

**Programs:** 3 Auto Programs (Relax, Refresh and Stretch Mode)

**Massage Modes:** Kneading, Tapping, Shiatsu, Knocking, Pressing, Knead & Knock Combination, Rolling, Stretch, Finger Knead, Back Rubbing, 3 Auto Programs (Relax Mode, Refresh Mode, Stretch Mode)

**Purpose of Use :** Massage Chair - relaxing muscles, Moving, Improving blood flow temporarily alleviate joint pain, enhance detoxification

**Special Features:** Full Body Air Pressure massage at 3 Degrees Variable Intensity, Extendable Footrest, Heating with Smart, Thermostat for overheating protection, Foot Rollers, Intelligent 3D Massage Roller, Intelligent body scan technology, Acupoint and pulse Tracking, Patented micro-spatial intelligence slide forward

**Zero Gravity:** Zero Gravity massage chair, **Air Bags:** 32, **Airbag Intensity:** 3 Degrees, **Power Source:** 220-240V, **Alternating Current:** 50/60Hz, **Power Consumption:** 120W, **Wall Space:** 5cm

**Rollers:** 4 Massage Rollers

**Maximum Operating Period:** 30 minutes

**Available Colour:** Black

**Rail:** L-Rail Design, **Music/Connect/Control:** LCD Remote, **Max User Weight:** 120KG, **Accessories:** LCD Remote, User Manual in English, **Massage Length:** 136cm, Super Long Massage Track

**Noise level:** ( $\leq$ ) 60(dB) within 30cm, **Upright Position:** 143 x 76 x 112cm, **Recline Position:** 180 x 76 x 81.5cm, **Net weight:** 72KG, **Gross Weight:** 85KG, **Warranty:** 1 Year



## PMC-2500L<sup>®</sup>

### Massage Chair Zero Gravity and L Shape

#### 3D intelligent Massage Technology

Professional super long L shape massage chair 120CM super long massage stroke, from the head to the buttock directly. L shape design fits your body back shape perfectly, deeply massage the neck and shoulders, deeply massage your waist

#### Zero Gravity Luxury massage chair

Six-roller back massage mechanism performs whole massage from Neck to Buttock.

Rolling massage for sole along with fast reversal technique.

Kneading, Tapping, Knocking, Shiatsu, finger kneading, backrub, Pressing and other massage programs.

Auto detects function. Confirms the massage range according to the body shape.

There are 54 air bags distributed in shoulder, waist, seat, leg rest, footrest and armrest can affect very comfortable air pressure massage function.

Extendable footrest, Maximum 22cm. Special design for people with different height.

Patented micro-spatial intelligence slide forward, save the Space. With music 3 separate control panel, LCD remote control

Available colour : Coffee Brown and Brown, Heating Function on waist and Back

Max User Weight: 135KG



## PMC-4768L<sup>®</sup>

### Intelligent 4D with with Zero Gravity and L Shape



Patented 4D intelligent massage technology
Patented Heating back massage rollers provide heating function
Multi angle curve rail. Body curve rail Multi-angle back-hip one piece massage. Super long massage stroke fits your body back shape perfectly
Zero Gravity luxury massage chair
Eight-roller back massage mechanism performs whole massage from Neck to Buttock
Rolling massage for sole along with fast reversal technique
Feet Heating, Auto detects function
Kneading, Tapping, Knocking, Shiatsu, finger kneading, backrub, Pressing and other massage programs
Acupoint and pulse Tracking makes the massage more Accurate
Patented micro-spatial intelligence slide forward, save the space.
There are 76 air bags distributed in shoulder, waist, seat, leg rest, footrest and armrest can affect very comfortable air pressure massage function
Extendable footrest, Maximum 15cm with different height sensor
Stretching whole body Function using Thai massage technique
Holographic feel makes the massage more comfortable
16. 3 separate control panel: 7 inch tablet control panel, Imbedded
Control panel and control from any mobile phone by downloading app
Ionizer air purification technology can absorb harmful substances in the air, purify the local air quality.
Innovative Leg Rubbing function. Leg muscles rubbing massage can effectively improve the leg pain effect, restore health and vigorous of legs
Mobile App via Bluetooth (Android & iOS), Convenient Wireless Full Color LCD Remote Control and User Voice Command, following user's voice guidance by intelligent voice activation technology can make you enjoy a comfortable massage service
Bluetooth Music function
Weight: 160KG
Available colour: Rose Gold



**PMC-4900<sup>®</sup>**
**4D Plus Massage Technology with S & L Shape Track**

Patented 4D Plus intelligent massage technology makes the massage stronger & deeper

S/L roller path: 130 cm length, allows the back roller mechanism moves from head to buttocks. Feet & Calf roller: Perform a reflexology experience.

Body sensing: detect body height, adjust back roller automatically to fit user.

Sliding forward while reclining, help saving placement space.

Full body air massage, relief tension

Rocking rotating, gives the classic rocking chair feeling for total relaxation by moving the upper part of the chair back and forth rhythmic.

U Shape neck design, Kneading shiatsu for temple. LED light: create a warm environment for massage.

Equipped with 114 cells of air bags, offering full body air compression massage, which adjustable intensity and separated on/off option for each area. Equipped with carbon fiber heating pads, located under the back, buttock, calf and ankles area which helps users to keep warm and releases fatigue. Extendable footrest, Maximum 22cm.

Stretching whole body Function using Thai massage technique.

Holographic feel makes the massage more comfortable

2 separate control panel: Smart Phone control by an upgradable App makes this our easiest control system to date, LCD Remote control panel Bluetooth system for music and wireless remote

Net Weight: 134KG

Available colour: Red & White





## PMC-5000®

### Exquisite Style 4D Massage Chair



**Technology:** 4D Plus intelligent technology

**Air Bags:** 32 Dual Layer Airbags

**Rollers:** Four Roller

1. Patented 4D Plus intelligent massage technology makes the massage stronger and deeper

**2. Super Long L-shape Massage Track:** 125 cm length, provides 60% more massage area on the back compared with general massage track and allows the back roller mechanism moves from head to buttocks, whereby expanded the core massage area greatly and a larger massage range, and fit the body shape better than ever. The curve is ergonomically designed, which makes the neck and waist massage more powerful than ever neck and waist massage more powerful than ever.

**3. Zero Gravity luxury massage chair:** A zero gravity position can help to relieve stress on the back spine and allows for a deeper, more intense massage experience. Plus, it promotes circulation in the legs and reduces swelling.

**4. Calf Massage:** Innovative technology performs rubbing massage of your legs. The sophisticated mechanism locates in the middle which moves up and down while the airbags at both sides clamp your calf, performs rubbing massage to improve ache of your legs. It is also helpful to slim your legs.

**Maximum Operating Period Position:** 120 x 81 x 126, **Reclined Position:** 171 x 81 x 91cm, **Net Weight:** 82KG, **Gross Weight:** 102KG, **Rollers:** Eight Rollers, **Shape:** S shape, **Warranty:** 1 Year

**5. Feet Roller:** Performs scraping and rolling massage on the sole with 3 rows of roller giving a reflexology experience which helps to relieve foot stress and tiredness.

**6. Rotating Airbags:** The shoulder Airbags can be rotated in order to meet different needs.

**7. Body sensing:** Detect body height, adjust back roller automatically to fit the user.

**8.** Automatically slid forward max. by 30cm when reclining the backrest, to save your previous space and arrange aesthetically in your house.

**9.** The built-in leg rest motor will offer GUGASHA massage because of the zero second waiting during changing the moving direction Rocking rotating, gives the classic rocking chair feeling for total relaxation by moving the upper part of the chair back and forth rhythmic.

**10.** Full body air pressure massage, relief tension.

**11.** All the massage balls of the back roller mechanism are made of silica gel material and the mechanism has equipped with multi-sensors, thus it can offer a more gentle and accurate back massage.

It has 9 Auto massage modes - Sports Refresh .Extension .Rest & Sleep. Work Relief .Neck & Shoulder .Waist & Spine .Deep Shiatsu. Healthy Breath.

**6 massage methods** - Combination .Tapping .Knocking. Rhythm. Kneading .Shiatsu

**4 Position Adjustments:** Whole, Partial, Point & Width Adjust.

The Speed, Intensity, Range and width of the mechanism can be adjusted per user's preference.

**12. LED light:** Create a warm environment for the massage.

**13.** Advance, the cutting-edge chip provides fast function and No waiting time for direction change.

**14.** Equipped with 32 Dual Layer airbags, offering full body air compression massage, which adjustable intensity and separate on/off option for each area. Equipped with carbon fiber heating pads, located under the back, buttock, calf and ankles area which helps users to keep warm and releases fatigue.

**15.** Extendable footrest, Maximum 15cm. Special design for people of different height.

**16.** Unique Stretch Function stretches the whole body using Thai massage technique.

**17.** Holographic feel makes the massage more comfortable.

**18. 2 Separate Control Panel:** Smart Phone control by an upgradable App (Android and iOS) makes this our easiest control system to date, TFT Wireless Remote Control.

**19.** Bluetooth Pairing system for music. A Bluetooth chip allows users to play music on the chair by pairing their device with the massage chair.

**20.** USB port for charging.

**21. Massage Time Options** - 10, 20 or 30 minutes.

**22. Net Weight:** 151KG

**23. Available Coulor:** Black with Coffee





## IF-839<sup>®</sup>

### Foot Massager

<b>Power</b>	65 Watts
<b>Voltage</b>	220V - 240V
<b>Amperes</b>	5 Amps
<b>Product Size</b>	59 x 53 x 60cm
<b>Operating Time</b>	15 minutes
<b>Colour</b>	Golden
<b>Warranty</b>	1 Year Manufacturer Warranty



Bring your tired feet back to life.

- 1) Completely surrounds the feet and ankles to deliver massage that is relaxing, soothing and energizing all at once
- 2) 2 deep-kneading Shiatsu rollers help relieve tightness and stimulate reflexology zones of feet
- 3) Rocker Massage Technology in the foot beds delivers refreshing percussion massage to the soles of the feet (and feels incredible!)
- 4) Dynamic Squeeze™ air massage gently squeezes away tension.
- 5) Optional vibration enhances your overall massage for deeper relaxation
- 6) Selectable heat helps to further relax feet for a more effective massage
- 7) Choose from 3 auto massage programs (Soothe, Pulse and Energize) or use the control panel to create a custom massage
- 8) High, Medium and Low massage intensities
- 9) Built-in cord wrap keeps things tidy
- 10) Zip-out linings for easy cleaning
- 11) Includes power adapter



## IF-868®

### Foot and Leg Massager



<b>Power</b>	95 Watts
<b>Voltage</b>	220V - 240V
<b>Frequency</b>	50/60Hz
<b>Product Size</b>	59 x 53 x 60cm
<b>Operating Time</b>	15 minutes
<b>Color</b>	Brown
<b>Warranty</b>	1 Year Manufacturer Warranty

Three roller of kneading massage roller on feet part. Shiatsu massage on feet. 16 sets of air - compression bag. All - wrapped air bags, comprehensive air-compression. Carbon cloth heater, keep a steady temperature. Heating therapy.

#### Features:

**Fashionable, Dexterous Design:** Optimal artful design, color variety, easy to fit in furniture and house.

**Airbag Pressure Massage And Rollers Massage to the Bottom of Foot:** It imitates air pressure technology from message chair with tender massage intensity and flexible massage functions. Special rollers are equipped on the foot bottom to simulate acupuncture points in the foot. Working together with air pressure, it helps achieve the best massage effect.

3 Level of Intensity and 5 Programs Lead to 17 Kind of Different Massage Combination: you can choose your desired massage intensity and program to achieve the most comfortable massage effect

Upper Part Multi Angle Adjustable: It adopts double-parts design for massage, the angle of upper part can be adjusted from 0 to 120 degrees.

**Far Infra-Red Heat:** With Far Infra-red heat function, it can warm the body and promotes blood circulation.

**Detachable Fabric Cover:** Detachable fabric cover is removable and washable.

**Safety:** The airbags can shrink automatically to prevent legs from being stuck when the power is off in a sudden.

**Benefits:** Reduce the pressure of foot and leg, improve the flexibility of muscle, beautify the curve of leg, stimulate blood circulation, ease the pain after exercise, stimulate the points, remove fatigue and improve the quality of sleep a variety of three-dimensional massage.

We move shiatsu rolling foot massage unite into this leg massager.

Leg & knee massage simulate professional music therapists, pinch, rub, rub, point, according to a variety of massage techniques, to achieve three-dimensional linkage leg foot massage.

Dimensional computer carefully controlled massage intensity, do not worry about non-professional masseur hurt your body.

All around wrap airbags

360-degree wrap around airbags with more powerful massage and a wider care air-compression.

Circulating air pressure pulse controlled by integrated chip. With soft and comfortable feeling.

Completely breaking the traditional weakness of foot massage machine with hard contacts to help eliminate leg fatigue caused by prolonged standing, leg reshape and curve good shape.

6 groups of carbon fiber heating cloth, warm your legs, feet, 50 degree temperature heating well protected legs and foots from the cold breath of intrusion, take care of your health.

Leg & knee massager set up eight groups of carbon fiber heating device at the knee and ankle, simulate the traditional cupping heating, warm legs and foot's corresponding parts



## IF-8005<sup>®</sup>

### Foot and Leg Massager

<b>Power</b>	88 Watts
<b>Voltage</b>	220V - 240V
<b>Amperes</b>	5 Amps
<b>Motor</b>	4 Motor
<b>Massage Speed</b>	Low, Medium, High
<b>Operating Time</b>	15 minutes
<b>Product Size</b>	48 x 42.5 x 42.5cm
<b>Warranty</b>	1 Year Manufacturer Warranty

#### Special Features

1. This Elegant Massager is Engineered with utmost care and is capable of providing simultaneous massage to foot, Ankles, Calves and gives a superb massage experience at Home.
2. Strong Kneading action penetrates deeply into muscles of feet, ankles and calves and relieves stress of tired leg muscles.
3. Pressure Nodes located under feet stimulates the reflex points of sole and helps in relaxation of leg muscles.
4. Air Pressing Function of massager, gently presses the calves and feet with care and relieves tiredness of muscles.
5. The Vibration Mode relaxes the underlying muscles and creates a wider sense of relaxation of leg muscles.
6. The Heating therapy dilates the vessels and promotes blood flow through veins hence helping in relaxing the tired muscles.
7. The massager reclines up to 45 Degrees to ensure total comfort of user and can experience a leg massage in seated/Reclined condition.
8. The intense Roller Reflexology massage helps to relieve muscle tension & activates the pressure points and assists in recharging with energy to entire Body

## IF-8008<sup>®</sup>

### Foot and Leg Massager

<b>Power</b>	88 Watts
<b>Voltage</b>	220V - 240V
<b>Amperes</b>	5 Amps
<b>Motor</b>	4 Motor
<b>Massage Speed</b>	Low, Medium, High
<b>Operating Time</b>	15 minutes
<b>Product Size</b>	48 x 42.5 x 42.5cm
<b>Warranty</b>	1 Year Manufacturer Warranty



#### Special Features

1. This massager is designed with great care and can simultaneously massage foot and calves giving you total relaxation at home at your leisure time.
2. The massager reclines up to 45 Degrees to ensure total comfort to its user and can have a leg massage in seated/Reclined condition.
3. Intense Roller Reflexology massage helps to relieve muscle tension and promotes Blood circulation.
4. The Heating Function dilates the vessels and promotes blood flow through veins and provides more oxygen to healing tissues.
5. The vibration therapy relaxes the underlying muscles and creates a wide sense of relaxation of leg muscles.
6. The pressure Nodes Located under the feet stimulates the reflex points of sole and helps to relax muscles.
7. The unique Air pressing Function of Massager relieves pain of foot and calves and relaxes the leg muscles.

## IF-8009<sup>®</sup>

### Foot and Leg Massager



<b>Power</b>	80 Watts
<b>Voltage</b>	220V - 240V
<b>Frequency</b>	50 - 60Hz
<b>N.W.:</b>	13KG
<b>G.W.:</b>	14KG
<b>Operating Time</b>	15 minutes
<b>Product Size</b>	55 x 40 x 38cm
<b>Warranty</b>	1 Year Manufacturer Warranty

#### Special Features

- 1) Instep and heel with air pressure kneading massage.
- 2) Shiatsu, Kneading, Vibration, Rolling, and Heating
- 3) 3 custom modes of foot massage, 3 intensities of calf massage and 3 levels of heating.
- 4) 8 massage discs for feet and 4 discs for calves providing 360 degree massage
- 5) Foot massage and calf massage can work separately or simultaneously.
- 6) The ergonomically design is adopted to replicate ancient massage and to target the sensitive area of the calves and soles of the feet.
- 7) The kneading and rolling actions go deep into the different layers of muscles of your calves, feet, ankles and soles, leaving your rejuvenation and relaxation.
- 8) Kneading and rolling massage target vital reflex points on feet and soles, achieving positive reflexology effects.
- 9) Stimulates blood circulation, thereby preparing and warming the muscles.
- 10) Relieves tension and reduces stress
- 11) Relieves sore and tired feet effectively.
- 12) Helps to tone, shape and beautify your calves and feet.
- 13) Light-weighted, Portable and washable fabric cover.

## IF-8010<sup>®</sup>

### Foot Massager

<b>Power</b>	50 Watts
<b>Voltage</b>	220 volts AC
<b>Amperes</b>	5 Amps
<b>Color</b>	Golden
<b>Operating Time</b>	15 minutes
<b>Product Size</b>	41.5 x 34.5 x 23cm
<b>Warranty</b>	1 Year Manufacturer Warranty



#### Special Features

1. The Unique Air Pressing Function of massager relieves pain of foot and relaxes tired muscles.
2. Intense Rolling and Roller Reflexology massage helps in relieving muscle tension and promotes Blood circulation.
3. Scrapping Function of massager ensures pain Relieving effect on Myalgia and chronic pain and improves blood stasis and inflammation.
4. The Kneading function gives you most relaxing & revitalizing massage experience.
5. The Heating Function of sole dilates the vessels, and allows blood to more easily stream through veins & more oxygen is absorbed by the healing tissues.



**IF-8009®**
**Foot and Leg Massager**

<b>Power</b>	55 Watts
<b>Voltage</b>	24V DC
<b>N.W.:</b>	11.05KG
<b>Color</b>	Brown / White
<b>Operating Time</b>	15 minutes
<b>Product Size</b>	47 x 43 x 26cm
<b>Warranty</b>	1 Year Manufacturer Warranty

**Special Features**

1. Elegant design with classy lacquer surface radiates fashionable qualities.
2. Unique styling and acupoint distribution fits to the human leg and foot structure, providing professional leg and foot massage just like bringing a professional masseuse at your home.
3. The innovative foldable design is stylish on the appearance and space-saving.
4. Equipped with double sensitive touch panel
5. Nano, removable and washable foot & leg cloth cover
6. Various massage technique such as kneading, scrapping, shiatsu, airbag press, warm foot, etc.
7. Light-weighted and portable
8. Double safety protection system makes you feel secure while using this massager. When the massager is overheating or the circuit is overloaded, the circuit will break off immediately.



## VP-500<sup>®</sup>

### Power Fit Massager



<b>Display</b>	Three Window LED Display for Time, Speed & Pulse
<b>Speed</b>	50 Level
<b>Motor</b>	1 DC Motor
Ideal for warming up	
Enhances blood circulation	
Reduces abdominal & thigh fat	
<b>Rated Voltage</b>	220V - 240V
<b>N.W.</b>	27KG
<b>Product Size</b>	116 x 74 x 26cm
<b>Warranty</b>	1 Year Manufacturer Warranty

## VP-700<sup>®</sup>

### Power Plate - 3D vibration Plate with 2 Motors

<b>Rated Power</b>	500W
<b>Speed Range</b>	1 - 20 Level
<b>Function</b>	1 Oscillation movement, Linear movement, Combination movement
<b>Time</b>	1 - 5 minutes
<b>Working Mode</b>	1 Manual working Model and 3 Automatic working
3 in 1 function, 2 Motors	
The machine can be controlled by Pressing the "Control Panel" on the Machine, or use "Remote Control"	
<b>N.W.</b>	23KG
<b>Product Size</b>	80 x 45 x 48cm
<b>Warranty</b>	1 Year Manufacturer Warranty







### GH-123<sup>®</sup>

Dumbbell Rack



Sturdy Design

Made form Heavy Duty Cast Iron Angles

Can hold 8 Pairs of Dumbbells

### GH-125<sup>®</sup>

Barbell Rack



Sturdy Design

Made form Heavy Duty Cast Iron Angles

Can hold 10 barbells

### GH-127<sup>®</sup>

Barbell / Handle Rack



Sturdy Design

Heavy duty construction

### GH-128<sup>®</sup>

Dumbbell Rack



Sturdy Design

Can hold 10 pairs of Dumbbells

### GH-207<sup>®</sup>

Dumbbell Rack



Sturdy Design

Made form Heavy Duty Cast Iron Angles

Can hold 4 Pairs of Dumbbells

### 3-TIER

Dumbbell Rack







### PDS-10KG®

Dumbbell Set with Non-Slip Grip for Home Use



Plates Included: 2 x 2KG + 4 x 1KG  
1 x 14T Chromed Bar and 2 x Star Collars with Rubber Grip

### PDSC-10KG®

Dumbbell Set Metal Plates + Dumbbell Rods Home Gym



Plates Included: 2 x 2KG + 4 x 1KG (Plate have two colour)  
1 x 14T Chromed Bar and 2 x Star Collars with Rubber Grip

### PDS-15KG®

Dumbbells Set Metal Plates + Dumbbell Rods Home Gym



Plates Included: 4 x 0.5KG + 8 x 1.25KG  
2 x 14T Chromed Bar and 4 x Star Collars with Rubber Grip

### PDSC-15KG®

Dumbbells Set Metal Plates + Dumbbell Rods Home Gym



Plates Included: 4 x 0.5KG + 8 x 1.25KG (Plates have two color)  
2 x 14T Chromed Bar and 4 x Star Collars with Rubber Grip

### PDS-20KG®

Dumbbells Set Metal Plates + Dumbbell Rods Home Gym



Plates Included: 4 x 0.5KG + 4 x 1.25KG + 4 x 2.5KG  
2 x 14T Chromed Bar and 4 x Star Collars with Rubber Grip

### PDS-20P®

PVC Coated Cement Dumbbells Set



Plates Included: 2KG \* 4, 1.5KG \* 4, 1.25KG \* 4, 2 x 16inches Rods  
4 x Collars, Cement + PVC Coated,

### PDS-20P+®

Adjustable PVC Cement Dumbbells Set



Plates Included: 2KG \* 4, 1.5KG \* 4, 1.25KG \* 4, 4 x Collars,  
2 x 16inches Rods, 1 x 15inches Barbell Rods, Cement + PVC Material

### PDKS-20P®

Adjustable PVC Cement Kettlebell Dumbbells Set



Plates Included: 2KG \* 4, 1.5KG \* 4, 1.25KG \* 4, 4 x Collars, Cement+PVC  
2 x 16inches Rods, 1 x 15inches Barbell Rod, 1 x Kettlebell Rod

### PDS-30®

Baking Iron Dumbbells Set



Plates Included: 4 x 1.25KG + 2 x 2KG + 2 x 5KG  
2 x 14T Chromed Bar and 4 x Star Collars, 1 x Barbell with Rubber Grip

### PDS-30C®

Chrome Iron Dumbbells Set



Plates Included: 4 x 1.25KG + 2 x 2KG + 2 x 5KG  
2 x 14T Chromed Bar and 4 x Star Collars, 1 x Barbell with Rubber Grip

### PDS-50KG®

Dumbbells Set Metal Plates + Dumbbell Rods Home Gym



Plates Included: 4 x 1.25KG + 6 x 2.5KG + 4 x 5KG  
2 x 14T Chromed Bar, 60T Chromed Bar in 2 Sections, 6 x Star Collars,  
1 x Barbell Connector with Rubber Grip and Black Paint Finish

Rubber Coated Solid Dumbbells Dumbbells M.S.Chrome



Tear Proof, Sound Less & Bouncy Effect  
Available Size (in KG ): 2.5, 5, 7.5, 10, 12.5, 15, 17.5, 20, 22.5, 25, 30, 35, 40,  
45, 50

### Rubber Coated Hexagon Dumbbells



Tear Proof, Sound Less & Bouncy Effect

Available Size(in KG): 2.5, 5, 7.5, 10, 12.5, 15, 17.5, 20, 22.5, 25, 30, 35, 40, 45, 50

### Dumbbells M.S.Chrome



Tear Proof, Sound Less & Bouncy Effect

Available Size (in KG ): 2.5, 5, 7.5, 10, 12.5, 15, 17.5, 20, 22.5, 25, 30, 35, 40, 45, 50

### Dumbbells Plate Type



Tear Proof, Sound Less & Bouncy Effect

Available Size(in KG): 2.5, 5, 7.5, 10, 12.5, 15, 17.5, 20, 22.5, 25, 30, 35, 40, 45, 50

### Kettle Bell Dumbbell



A legendary Russian exercise device, the kettle Bell has long been a favourite for those seeking a special edge in strength and endurance.

Available Size (in KG ): 2, 4, 8, 12, 16, 20, 24, 28, 32, 36

### Vinyl Dipping Triangle Dumbbell



Available Size(in KG): 1, 2, 3, 4, 5



# WEIGHT PLATES

## Rubber Coated Olympic (50mm) Plates - Coloured



Metal Ring for durability and also available in 29mm hole

Tear Proof, sound less & bouncy effect

Available Size (in KG ): 1.25, 2.5, 5, 7.5, 10, 15, 20, 25

## Rubber Coated Olympic (50mm) Plates - Black



Metal Ring for durability and also available in 29mm hole

Tear Proof, sound less & bouncy effect

Available Size (in KG ): 1.25, 2.5, 5, 7.5, 10, 15, 20, 25



## Standard M.S Plate - Chrome Plate

Also available in Olympic (50mm) hole

High quality chrome finish for long lasting

Available Size (in KG ): 1, 1.25, 2, 2.5, 3, 4, 5, 7.5, 10, 12.5, 15, 17.5, 20, 25

## BSD-2

### Digital Personal Bathroom Body Weight Scale



#### Features:

- 4 digits in LCD display
- LB/KG/ST Conversion
- Overload and low battery indication
- 1 × CR2032 Lithium Battery Power
- 180kg /396lb Capacity
- 0.1kg/0.2lb Division
- ABS Plastic part, 4 tempered glass platform



## Digital Personal Bathroom Body Weight Scale



### Features:

- 4 digits in LED backlight display (72\*3cm)
- LB/KG/ST Conversion
- Overload and low battery indication
- 2×AAA Battery Power
- 180kg /396lb Capacity
- 100g Division

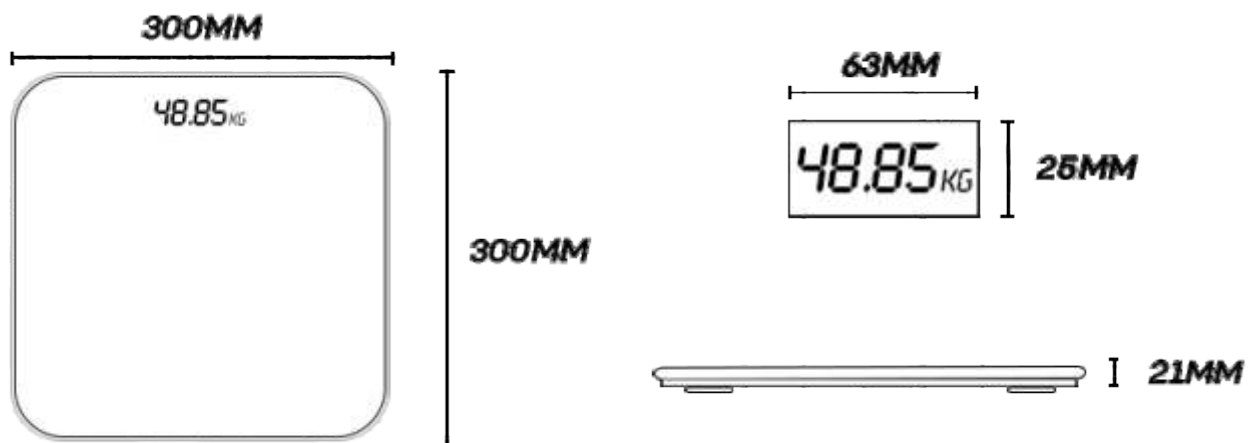



# BCA-07

## Digital Body Composition Analyzer



### Body Composition Data:

Body fat, Body hydration, Body muscle, Body bone, Calories indication, BMI Indication

### APP Features:

- 12 Memory user
- Auto recognize family Members
- LB/KG/ST Conversion
- 4 digits in LED backlight display (72\*31mm)
- Calendar based history review
- Social sharing of measurement and moments.
- Overload and low battery indication
- 2\*AAA Battery Power
- 180kg/396lb Capacity
- 100g Division
- ABS Plastic part,6mm tempered glass platform



## Smart Device BCA-130 Bluetooth Smart Scale



Works with "FEEL-IT", Free download at  and  Google play

Engineered for the health-conscious, the Powermax BCA-130 Bluetooth Smart Scale provides in-depth measurements of not only your weight, but also other key measurements that can aid you in optimum weight management. Bioimpedance is the common method used by household scales to calculate body composition. Powermax BCA-130 uses the Bioimpedance method by using 4 sensitive stainless steel electrodes to determine the hindrance of electrical flow through the body, and uses that to calculate the total body water. From the total body water, it can estimate the 13 key body compositions.

### Body Composition Data:

Weight, BMI, Body Fat, Fat-Free Body Weight, Subcutaneous Fat, Visceral Fat, Body Water, Skeletal Muscle, Muscle Mass, Bone Mass, Protein, BMR, Metabolic Age

### APP Features:

- App support Android & iOS
- Weighing Reminder
- Unlimited number of User
- Auto recognize family Members
- Auto LB/KG/ST recognition
- Cloud based data storage to ensure safety
- Connect to Apple health kit/Google Fit/Fitbit and more
- Password App Lock to ensure privacy
- Calendar based history review
- Social sharing of measurement and moments.



### Note:

1. Keep your App running while stepping on the scale platform to measure data.
2. Stepping on the scale without bare feet or Bluetooth pairing to App, would only measure the body weight

# BCA-150

## Smart Bluetooth Body Fat Scale



This digital scale is used to determine a person's weight. Furthermore, it is possible to measure, BMI body fat, water, muscle, and bone percentages and to determine your recommended daily calorie intake. This digital scale should not be used outdoors or in tropical climates. This digital scale is not designed for commercial use or operation in a company. Use the digital scale only for private purposes in living areas as any other use is not as intended. These digital scales meet all relevant norms and standards in relation to CE conformity.

### Body Composition Data:

Weight, Body Fat, Body Water, Visceral Fat, BMR, BMI, Muscle, Bone Mass, Metabolism, Protein, Obesity Degree, Body Age, Weight without Fat

### APP Features:

- App support Android & iOS
- Weighing Reminder
- 810.BLE Module Memory user
- Auto recognize family Members
- LB/KG/ST Conversion
- Cloud based data storage to ensure safety
- Connect to Apple health kit/Google Fit/Fitbit and more
- 4 Digits in LED Display
- Calendar based history review
- Social sharing of measurement and moments.
- Overload and low battery indication
- 4×1.5V AAA Battery Power
- 180kg/396lb Capacity



### Note:

1. Keep your App running while stepping on the scale platform to measure data.
2. Stepping on the scale without bare feet or Bluetooth pairing to App, would only measure the body weight



# YOGA MATS



<b>Size</b>	2 x 6 feet
<b>Thickness</b>	4mm and 6mm
<b>Colour</b>	RD, GY, PK, BL, Available in 4 color
<b>Material</b>	PVC
<b>Warranty</b>	1 Year Manufacturer Warranty



## TREADMILL MAT



Size	177.5 x 75cm
Thickness	2mm
Colour	Black
Class	A



# VOSTA V3 VOLTAGE STABILIZER

Engineered for Heavy Treadmills and Home Use Appliances



Vosta V3 Voltage Stabilizer for Treadmills ensures optimal protection and performance of your equipment. With this voltage stabilizer there is no need to worry about voltage fluctuation.

## Features:

- Recommended for treadmills up to 3.0HP AC/DC motor
- Full protection design for Over Voltage, Under Voltage, Overheat, Short Circuit and Overload to protect your equipment
- Digital LCD display, continuously displays input & output voltage with 3 LED indicators
- Integrated with Zero cross switching technology with High Efficient Toroidal Transformer
- MCU controlled circuit for precision and regulated output
- 6s to 180s of integrated delay function
- CE certified
- Warranty - 3 Year Powermax Domestic India Warranty

## Specification:

- Input Voltage Range: 140~260 VAC
- Input Frequency: 50/60Hz
- Output Voltage: 220 VAC
- Output Accuracy:  $\pm 8\%$
- Efficiency: 98%
- Phase: Single phase
- Delay Time: 6s/180s selectable
- Certification: CE
- Operation Temperature: 0°C ~ 40°C
- Storage Temperature: -15°C ~ 45°C
- Operation Relative Humidity: 10%~90% RH, non-condensing
- IP Class: Ip20
- Material:
  - Front Panel: Metal
  - Cabinet: Metal
- Output Connector: Socket
- Capacity: 2000VA / 1200W
- Cooling Mode: Natural
- Net Weight: 5.1Kg
- Dimension: 250 x 140 x 175mm



## Appliances :

Treadmill upto 3.0HP AC/DC motor  
 Refrigeration equipments: Fan, Refrigerator, Chest freezer, Cooler and Air conditioner  
 Kitchen appliances: Microwave oven, Rice cooker  
 Entertainment appliances: TV, DVD, VCR, DVB, HiFi  
 IT & Office equipments: PC, Workstation, Fax machine, Photocopier, Server  
 Heating systems: Gas boiler, Circulation pump



# VOSTA V4 DIGITAL STABILIZER

Engineered for Treadmills and Home Use Appliances



Vosta V4 Voltage Stabilizer for Treadmills ensures optimal protection and performance of your equipment. With this voltage stabilizer there is no need to worry about voltage fluctuation.

## Features:

- Input Voltage Range: 180~270 VAC
- Output Voltage: 220 VAC ( $\pm 9\%$  Accuracy)
- Recommended for treadmills 3.0HP and above AC/DC motor and home use appliances
- Full protection design for High Voltage, Overload, Under Voltage, Overheat, Short Circuit and Overload to protect your equipment
- Digital LED display, continuously displays input & output voltage with 3 LED indicators
- Integrated with Zero cross switching technology with High Efficient, 100% Copper Toroidal Transformer
- MCU controlled circuit for precision and regulated output
- CE certified

## Specification:

- Output Power : 4KVA
- Input Frequency: 50Hz
- Output Voltage: 200V-240VAC
- Output Accuracy:  $\pm 9\%$
- Efficiency: 95%
- Phase: Single phase
- Delay Time: 6s/180s selectable
- Operation Temperature: 0°C ~ 40°C
- Storage Temperature: -15°C ~ 45°C
- Operation Relative Humidity: 10%~90% RH, Non-condensing
- Stabilizer Type: Electromagnetic AVR Relay
- Output Connector: Socket
- Capacity: 4000VA / 1200W
- Cooling Mode: Natural
- Dimension: 200 x 190 x 100mm



## Appliances :

Treadmill up to 3.0HP and above AC/DC motor  
 Supported Up to 2 Ton Air Conditioner  
 Refrigeration equipment: fan, refrigerator, chest freezer, cooler and air conditioner  
 Kitchen appliances: microwave oven, rice cooker  
 Entertainment appliances: TV, DVD, VCR, DVB, HiFi  
 IT & Office types of equipment: PC, workstation, fax machine, photocopier  
 Heating systems: gas boiler, circulation pump

## **TREADMILL BUYING GUIDE**

### **Treadmill Buying Guide : Choose the Right Treadmill for You**

#### **But buyers beware!**

There are more treadmills on the market than any other kind of fitness equipment leaving you the consumer with a mind-boggling choice. This is a mixed blessing. There is now a good range of quality treadmills to choose from but there are many more treadmills out there that you should think very carefully about before spending you're hard earned cash.

#### **Consider the following.**

A good motor fitted to a quality treadmill will have a trade price of INR42000 plus. Yet there are cheap treadmills on the market selling for this price. To be fair even the cheapest treadmills will offer something to those on a tight budget but be warned, they may come with problems. Some of these machines have been designed to last not much more than 6 months because they think that people will not be using them for much longer than that. It sounds unbelievable but true. A lot of these fitness machines are sold on the web. They are bought over by the container from the Far East. The web site sells them off offering all kinds of guarantees then a few months down the line the web site disappears leaving you the consumer with no redress. So if you see a very low priced treadmill its a case of buyer beware.

The following tips will help you maximize your investment, prevent you falling into any traps and also help you reach your desired goals.

#### **Buying your Treadmill**

##### **1. Consider who will be using the treadmill and what their specific goals are.**

It is often the case that there will be more than one person in the family who will be using the treadmill. Discussing each person's goals will help make sure that you purchase workout equipment that will withstand the use of multiple family members and provide the adjustments to accommodate different size users. For example, going for the cheapest option or buying a low quality underpowered motorised treadmill is a common mistake, but one that can cause considerable problems, particularly if it is being used by both a 57 and a 107 Kg person. Also will the treadmill grow with you? In a very short time with regular use you will find your fitness improving and as it does so you will need more from your treadmill. Will it be able to accommodate this?

##### **2. Go to a specialist fitness store and test the treadmill.**

A specialist fitness equipment store should be able to offer a range of treadmills for you to try. They will also be able to show you how to use the treadmill properly and provide installation as well as show you how to do routine maintenance. Then test the exercise equipment yourself.

Almost any treadmill will feel and seem adequate if you just walk on it for a couple of minutes. Its only when you begin to put the treadmill through its paces by jogging or running on it, adding elevation and using different programmes will you start to see and feel the major difference in quality and comfort, even vibration and noise.

When you go to the store wear appropriate clothing so you can test the gym equipment properly. A good treadmill is a major investment. Take your time.

### Location & Space.

Consider where you are going to site your treadmill. There is no problem with putting a treadmill upstairs as long as you appreciate that someone running hard on it will cause some noise and vibration below. A garage is fine as long as its not damp, which would effect the electronics. Conservatories are popular, but if its south facing it may get to hot. If you have a gym room on the ground floor, which is something that is growing in popularity then you have the perfect solution. Space should not be too much of a problem today now that there is such a large range of folding treadmills available. Don't forget that a motorised treadmill is an electric treadmill and will therefore require power from an electric socket.

### Features.



Powermax Fitness  
Treadmill Console

#### Easily Navigable Console

When you look at the treadmill console does it make sense? Do you intuitively know how the buttons work? Is the screen large enough and the workout information easy to read? The sales person will show you the basics but when you get the treadmill home they will not be there to guide you, so make sure you feel comfortable that you will be able to use the console with ease.

#### Cushioned Deck

This is a major selling point for all treadmills now, but not all cushioning systems are the same. The ideal absorption system should be one that feels firm and stable when you run yet still forgiving. It should not feel soft and spongy and slap back at you. This kind of cushioning could cause knee injuries over time and also wear out quickly. Good quality treadmills from respected manufacturers provide cushioning that is researched based and can show evidence on why their system works. There should be methodology in the system other than simply putting in rubber spacers or dampeners. Some treadmills now come with orthopaedic belts, which subtly enhance the cushioning further. The only way you can be sure you like the feel of the cushioning is to test the treadmill. Remember anything that will make your workout more comfortable will result in you sticking with it and achieving your desired goals. eadmill and will therefore require power from an electric socket.



Continuous Duty  
Treadmill Motor

#### 1. Adequate Motor

This is where the confusion really starts. Don't be fooled by the 'bigger is always better' rhetoric. There is more to a treadmill motor than its size. What you should look for is a continuous duty HP motor (continuous duty is a measure of horsepower under regular anticipated use and is far more meaningful than 'peak' horsepower).



In reality 2.0HP and above should be sufficient for any user as long as the rest of the motorised treadmills components are of a high quality. For example a good cooling mechanism will reduce the heat generated by the motor and other major components, prolonging their life and reducing wear on these parts. A large motor with a poor cooling system is not a good combination as this will result in premature wear and poor performance. However a superior cooling system and quality electronics do not come cheap and this is why there is such a disparity in price of motorised treadmills. Try not to focus on just the 'big' or 'quiet' motor, instead look at the treadmill as a whole system, with matching components that work together. It is this that makes the difference between a bog standard cheap treadmill and a quality treadmill.

### Console Feedback

An array of feedback features is available on most motorised treadmills. It is tempting to buy one with everything but before you do, consider what is important to you and the other users of the treadmill and how you will use it. You will certainly need the basic information such as speed, distance, elevation and time. You then need to look for features that will motivate and challenge you such as pace and heart rate. If you get bored easily it may be worth investing money in a treadmill that has a range of different workout programmes, as this will help you stay motivated.



### Folding Mechanism

Folding treadmills use one or two hydraulic pistons to assist with the lifting and lowering of the running deck. Make sure the piston is good quality and does the job. The majority of foldable treadmills have what some brands call a 'softdrop' mechanism. This lets the running deck drop slowly and gently without any intervention from you. It was designed to prevent injury to young children who may have accidentally released the treadmill from its raised locking position. These work very well but again the quality of the piston is crucial. The locking device differs considerably from brand to brand. Some have a simple release handle conveniently positioned at shoulder height, others have a pivoting plate at the bottom of the treadmill that you have to push down with your foot and others have an annoying lever type piston combined support that you have to pull apart. They all work adequately but some are just easier to use. We are often asked if foldable treadmills are less stable than a platform (non-folding) treadmill. Years ago folding treadmills were very unstable compared with a platform treadmill and cheap treadmills still are today. But buy a quality folder and you will be hard pressed to feel the difference.

### Belt -

The belt should be long enough and wide enough to accommodate your running style, if you plan to do a lot of running then look for a belt with a width of 500mm (20") and a length of 1400mm (55").

### Speed -

The maximum speeds will vary between models. Mid range and commercial treadmills have maximum speeds of 20kph (12mph). To give you an idea of speed, world class runners run at an average speed of 20kph during a marathon!

### **Incline (Elevation) –**

If you plan to do a lot of uphill walking or running then look for a treadmill with an incline of 10%. Thankfully most mid range treadmills incline to 10% (some incline to 12%).

### **Maximum user weights –**

Always check the maximum user weight before you purchase. Budget running machines usually have maximum user weights of around 100kg whilst mid range treadmills have maximum user weights of around 130kg.

### **Accessories –**

You can purchase many accessories. At Powermax Fitness Superstore we offer accessories such as: Floor protector Mats, Extended treadmill warranties, Heart Rate Monitors and much more.

### **Remember the must haves when buying a Treadmill**

Easy to read and easy to use treadmill console

Cushioned Deck

Programmes and features on the treadmill that are meaningful to you

An adequate continuous duty HP motor, 2HP or above is best

### **Safety and Maintenance**

Running and walking on a moving piece of exercise equipment is very effective and simple, but for the raw beginner it can also feel unsafe and fraught with quality issues if you don't choose wisely.

#### **Safety Features**

Look for an emergency stop button on the treadmill that is easy to see and accessible, no matter what speed or incline you are running at. There should also be a safety tether key. This is a key that plugs into the treadmill console and has a cord that runs from it that attaches to your clothing. If this key is pulled out the treadmill will automatically stop. Therefore if you fall or faint then the treadmill will not continue running which could cause serious injury. A tether key is ideal for a beginner. Has the treadmill got heart rate features, feedback and interactivity? All these help towards a safe and effective workout. Make sure the treadmill has handrails that are comfortable to hold but are not intrusive. Can you run or walk without your hands or arms hitting them? Testing in store for several minutes will help decide this. Finally the belt speed should rise and fall in gradual increments, guaranteeing you are always in control. When buying fitness equipment, gym equipment or any type of workout equipment safety must always be a priority.

#### **Maintenance**

A treadmill will always require a little maintenance, after all a treadmill is a mechanical and electronic piece of moving exercise equipment. However on a quality treadmill the maintenance should be minimal. Once set up you should not be centring the belt or lubricating the running deck after every workout. A well- designed unit should take in normal wear and tear. Ask the salesman what is required. Some treadmills have reversible running decks. This means that if normal wear and tear takes its course on the running surface the deck can be flipped over, basically doubling the life of the running deck. This is something that can be done by a competent owner but it is always worth asking the store what they will charge to do it professionally. If you have bought quality, professional gym equipment then it may be worth paying that extra to get a professional to look after it. However on a quality treadmill this is something that will not be required for many years.



Treadmill Deck  
Lubrication and  
Maintenance

### Warranty

Today treadmill warranties are almost used as a marketing tool. Companies now compete to offer longer and more comprehensive warranties. This is all well and good as long as the manufacturer is still in business in 10 years time. At minimum the treadmill should have a 3 year motor warranty, 1 year electronics and 1-2 year labour cover. As with everything else and this is probably more so with a treadmill, you get what you pay for. A treadmill has to take an enormous amount of punishment compared to other fitness equipment. For anyone who has regularly visited a health club they have probably found that the one piece of equipment that is out of order more than any other is the treadmill. Therefore the better the quality the less likely you will need to use your warranty.

### Finally

Equally as important, does the dealers from whom you are purchasing the exercise equipment, have their own service staff that are trained and authorised by the manufacturer to service your fitness equipment. At Powermax Fitness we have our own dedicated service engineers who have years of experience.

### Why you should buy your treadmill from Powermax Fitness

- We offer an extensive range of treadmills, covering all budgets
- Your treadmill warranty: All treadmills come with a minimum 1 year parts and labour warranty. Many far exceed this with 3 and 5 year warranties depending on Models
- Treadmill delivery: Delivered direct to your door
- Treadmill installation: Treadmills can be very heavy that is why we would recommend our installation service. Installed by our own engineers.



## **PowerMax Fitness**

### **Never Compromises With Quality of Products.**

1. Powermax Fitness equipments are manufactured from heavy gauge Steel frame duly Powder coated for prevention from corrosion and adds longer life to the machine.
2. All electrical and electronic parts are CE approved for better life and confirm to IS standard.
3. Rollers of Treadmill are dynamically balanced for better life of the conveyor belt and Bearings and ensure smooth workout.
4. Termite and waterproof jogging board for better life of Treadmill.
5. Industrial Graded fasteners and wire ropes to withstand sudden loads.
6. Dust proof panels provided to protect precise electronic parts.
7. All Electrical controls are tested for safety of user from Electric shocks.
8. Belts and flywheels are provided with guards' for safety of the user.
9. Powermax products are Power saving and help to cut on electrical Bills.
10. Pads are constructed of thick, High Density Foam surrounded by top Grade upholstery for a firm contoured feel during workouts.



URBAN TREK™

VOSTA



MARVEL

CAPTAIN AMERICA | IRONMAN | HULK | SPIDER MAN | THOR

IMPORTED & MARKETED BY

**POWERMAX FITNESS**

مستورد وتسويقها

لياقة باور ماكس

 @powermaxindia

 @powermaxfitness

 @powermaxfitnessindia

 @powermax\_india

[www.powermaxfitness.net](http://www.powermaxfitness.net)